

# YEOMAN.

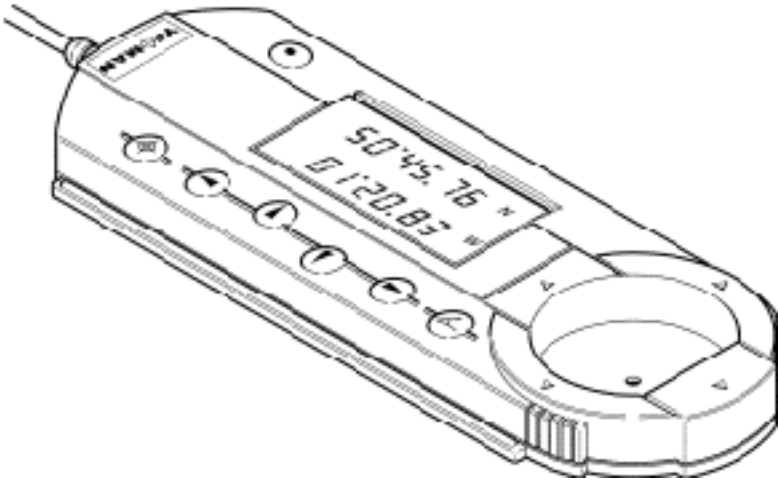

## YEOMAN Navigator Pro User Handbook

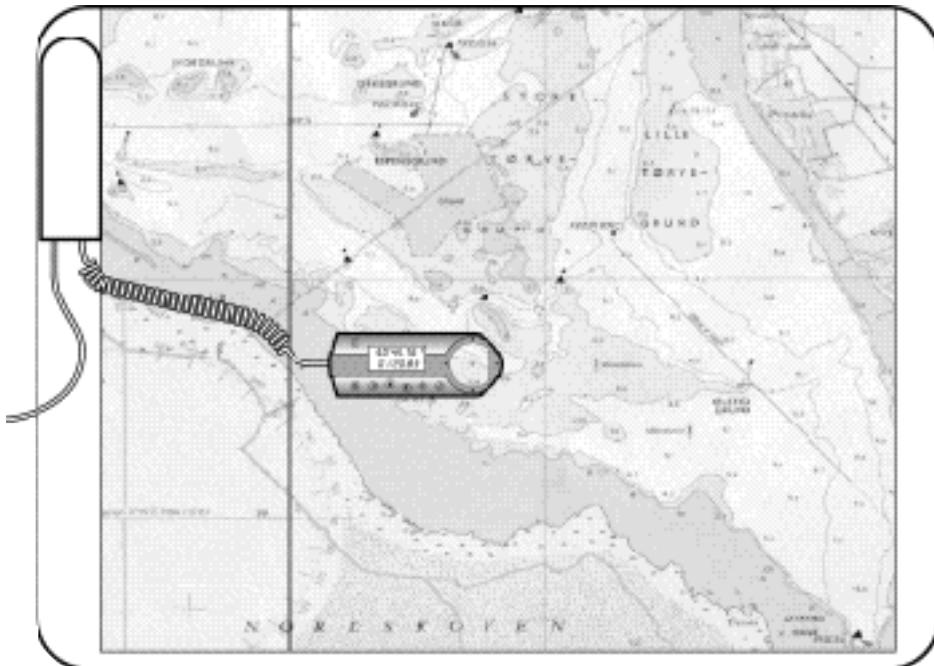



YEOMAN is a trademark of YEOMAN Group plc registered in the UK and USA and applied for in the European Union.

ChartKit® is a registered Trademark of Maptech Inc.

To the best of our knowledge and belief, the information contained within this handbook is correct and complete at the time of printing. However, YEOMAN reserve the right to change or improve the product according to technical developments. Any such developments will be described in addendum leaflets supplied with the product. YEOMAN accept no liability for information contained within this handbook which has been superseded by such addenda.

© YEOMAN 1998. All rights reserved.

This page is intentionally blank

# Introduction

## Brief Description

The YEOMAN Navigator Pro is a chart plotter that provides all the features of electronic plotting while using all the benefits of conventional paper charts. Its full capabilities are realised when interfaced to a GPS, LORAN or DECCA receiver, which enables the YEOMAN Navigator Pro to show vessel's position directly on the chart.

## About this manual

This Manual covers the operation of the following YEOMAN products:

- YEOMAN Navigator Pro

The YEOMAN product for coastal and blue water navigation. It contains pre-loaded chart libraries for UK small format charts Maptech ChartKits® and for some other countries and allows connection to suitable RADARs. The YEOMAN Mouse is then connected to the RADAR screen.

- YEOMAN GPS Navigator Pro

A self-contained 'plug & go' full function 12 channel GPS that provides all YEOMAN Navigator Pro functions.

## Package contents

- Chart mat with 2m integral power/data cable
- YEOMAN Mouse, with cable
- Practice chart
- Packet of 6 chart clips
- This user handbook.

The YEOMAN GPS Navigator Pro additionally contains:

- External GPS antenna with 9m cable and 5 pin plug

When you have confirmed that all these items are present within the package, please fill in and return the warranty registration card at the back of this manual. This will allow you to receive prompt and expert support if the need arises.

## **Warning**

The YEOMAN Navigator Pro chart plotter is a secondary navigational instrument which relies on data entered by the Navigator as well as primary satellite or radio navigation sources. Prudent navigational procedures indicate that primary navigational techniques such as visual bearings, soundings and the computation of an estimated position must, in all cases, be used in conjunction with secondary electronic navigational equipment such as the YEOMAN Navigator Pro.

## **Disclaimer**

YEOMAN and its Suppliers, Distributors and Agents shall not be liable for accidents occurring through misuse or malfunction of YEOMAN Navigator Pro units.

## **Safe compass distance**

Ensure that all elements of the unit are mounted at least one metre away from compass sensors.

## **Datum**

When using GPS, especially on larger scale charts, it is important to set the GPS Datum to the same as that of the chart being used. Failure to do so will result in incorrect position plotting.

## Projection

The YEOMAN Navigator Pro will work with all Mercator projection charts of all scales. It will also work with larger scale maps and charts of other projections, e.g. Transverse Mercator and Gnomonic. Small plotting errors may be apparent on non-Mercator charts with a scale smaller than 1:50 000.

## Patents

Patents granted in the following countries: Australia, Belgium, Denmark, France, Germany, Holland, Hong Kong, Italy, Japan, Luxembourg, Norway, Singapore, South Korea, Sweden, Switzerland, UK and USA.

The YEOMAN Navigator Pro is manufactured under licence from QUDOS BV.

## Warranty terms

YEOMAN warrants the unit to be free from defect in parts, material and workmanship for a period of 12 months from the date of purchase, either direct or from an authorised dealer. The benefit of this Warranty applies only to the original purchaser. Claims may not be made more than 18 months after despatch of the unit from our factory. Evidence of purchase, such as prompt return of the Warranty Card, will be required. This Warranty does not affect the statutory rights of the purchaser.

YEOMAN will repair or replace, at its option, any unit in respect of which a valid Warranty Claim shall be made on a return to YEOMAN basis. The cost of repair or replacement will be charged to the customer if the unit has been misused, damaged, tampered with by unqualified personnel or suffered severe environmental exposure including immersion in water.

## European Standard EN 60945 (CE Mark)



The YEOMAN Navigator Pro meets the standards set out in European Standard EN 60945: 1993 for marine navigational equipment, class B.

Under exceptional circumstances (e.g. a VHF transmission with aerial laid close to the YEOMAN Navigator Pro) it may be possible to cause temporary malfunction of the YEOMAN Navigator Pro. The YEOMAN Navigator Pro will recover normal operation when the source of the transmission is removed.

## Manufacturer

The YEOMAN Navigator Pro chart plotter is manufactured by YEOMAN who can be contacted as below:-

Web site <http://www.yeomangroup.plc.uk>

### Europe

YEOMAN

Premier Way, Abbey Park, Romsey, Hants SO51 9AQ, UK

Tel. +44 (0)1794 521079 Fax +44 (0)1794 521138

Email [sales@yeomanuk.plc.uk](mailto:sales@yeomanuk.plc.uk)

### USA

YEOMAN

222 Severn Avenue, Annapolis, MD 21403-2569, USA

Tel. 410 263 7335 Fax 410 263 8318

Email [yeomangrp@aol.com](mailto:yeomangrp@aol.com)

YEOMAN is a division of YEOMAN Group plc

## Table of Contents

<b>1. OVERVIEW .....</b>	<b>9</b>
1.1 The YEOMAN Mouse.....	9
1.2 Main YEOMAN modes .....	10
1.3 YEOMAN main mode map.....	11
<b>2. INSTALLATION .....</b>	<b>12</b>
2.1 General installation notes .....	12
2.2 Installation.....	13
2.3 Power up and initial test .....	14
<b>3. DEMONSTRATION MODE .....</b>	<b>15</b>
<b>4. BASIC OPERATIONS.....</b>	<b>16</b>
4.1 Keypad.....	16
4.2 Magnetic/True headings.....	18
4.3 Default hemispheres .....	18
<b>5. CHART LIBRARY AND REFERENCING .....</b>	<b>19</b>
5.1 User chart library .....	20
5.2 Pre-loaded chart library .....	22
5.3 Referencing the chart .....	23
<b>6. YEOMAN (PLOT) MODE .....</b>	<b>25</b>
<b>7. NAVIGATION MODE .....</b>	<b>27</b>
7.1 Integral GPS (YEOMAN GPS Navigator Pro only) .....	27
<b>8. WAYPOINT MODE.....</b>	<b>31</b>
8.1 Manual Waypoint entry .....	32
8.2 Sending Waypoints to a GPS.....	32
8.3 Autopilot output (YEOMAN GPS Navigator Pro only).....	33
<b>9. DEAD RECKONING .....</b>	<b>34</b>

<b>10. RADAR FUNCTIONS .....</b>	<b>36</b>
10.1 Overview .....	36
10.2 RADAR plotting.....	37
10.3 RADAR troubleshooting.....	39
<b>11. ADVANCED FEATURES .....</b>	<b>40</b>
11.1 Setup mode .....	40
11.2 Memory Reset .....	43
11.3 Freeze Mode .....	44
11.4 Lock mode .....	44
11.5 Two position referencing .....	44
11.6 Great circle navigation .....	44
<b>12. TROUBLESHOOTING .....</b>	<b>49</b>
<b>13. DATUM LIST .....</b>	<b>50</b>
<b>14. INTERFACING DETAILS .....</b>	<b>53</b>
14.1 YEOMAN Navigator Pro connections .....	53
14.2 YEOMAN GPS Navigator Pro .....	54
14.3 RADAR data change-over switch.....	55
<b>15. SPECIFICATIONS .....</b>	<b>56</b>
15.1 YEOMAN Navigator Pro.....	56
15.2 YEOMAN GPS Navigator Pro .....	57
<b>16. MOUNTING OPTIONS .....</b>	<b>58</b>
16.1 Mounting YEOMAN to chart mat top.....	58
16.2 Under table mounting .....	58
16.3 Under table mounting reversed.....	59
16.4 Mouse cable .....	59
<b>APPENDIX A: YEOMAN TO GARMIN GPS 120/GPS II/45 .....</b>	<b>60</b>
<b>APPENDIX B: YEOMAN TO GARMIN .....</b>	<b>61</b>
<b>120,125,126,128,130,135,215,220,225,230,235</b>	
<b>APPENDIX C: YEOMAN to Philips AP8 &amp; AP9 GPS .....</b>	<b>62</b>
<b>APPENDIX D: YEOMAN to PC .....</b>	<b>63</b>

# 1. Overview

## 1.1 The YEOMAN Mouse

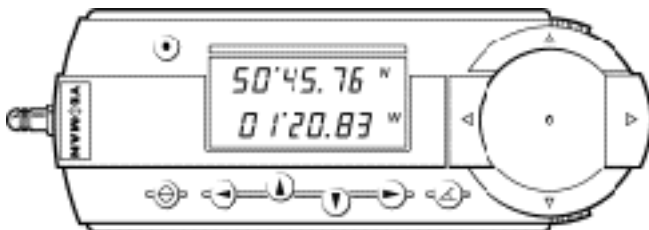

Plot Spot - the hole located in the centre of the lens which lets you plot a GPS or Waypoint position using a pencil.

Indicator arrows - the illuminated arrows representing, from the top in a clockwise direction, NORTH, EAST, SOUTH and WEST. These lights when illuminated, will guide the Plot Spot to a GPS or Waypoint position.

GPS - Global Positioning System. Throughout this manual "GPS" is used to refer to all electronic positioning systems, as GPS is the most widely used. Other systems such as DECCA and LORAN may be used instead.



The Enter key. To accept data entries.



The Scroll key. Moves between operating modes.



The Range and Bearing key. This key is used to display the range and bearing to or from the Mouse while in YEOMAN, Navigation or Waypoint modes.



The Shift keys (left/right keys). Use these keys to highlight individual digits to allow data entry. Also use these keys to scroll to Dead Reckoning mode.



The Numeric keys (up/down keys). Operation of these keys will increase/decrease any numeric entries.

## 1.2 Main YEOMAN modes

### 1.2.1 Chart select

Used to reference a chart on the YEOMAN Navigator Pro. A chart must be referenced before any action is possible.

### 1.2.2 YEOMAN (plot)

The latitude and longitude of the current Mouse position is displayed. Ranges and bearings between points can also be displayed.

### 1.2.3 Navigation

When interfaced to a GPS, its position will be displayed and the indicator lights will point to that position on the chart. Ranges and bearings to or from the GPS position can be displayed. Course and speed over ground can be displayed, as can Time To Go to any chart position.

### 1.2.4 Waypoint

A Waypoint can be entered and stored either directly off the chart or manually through the keypad. It can also be transferred directly to most GPS units. Up to 500 Waypoints can be stored and recalled by their allocated numbers.

### 1.2.5 Dead reckoning

This mode allows for the calculation and plotting of Dead Reckoning position.

### 1.2.6 Set-up

To set-up interfacing and other selectable parameters.

### 1.2.7 Great circle

This mode allows the plotting of a Great Circle course between two points and evaluates the total great circle distance. It will also plot Waypoints along the Great Circle track.

### 1.3 YEOMAN main mode map

This mode map shows the relationship between the main YEOMAN modes.

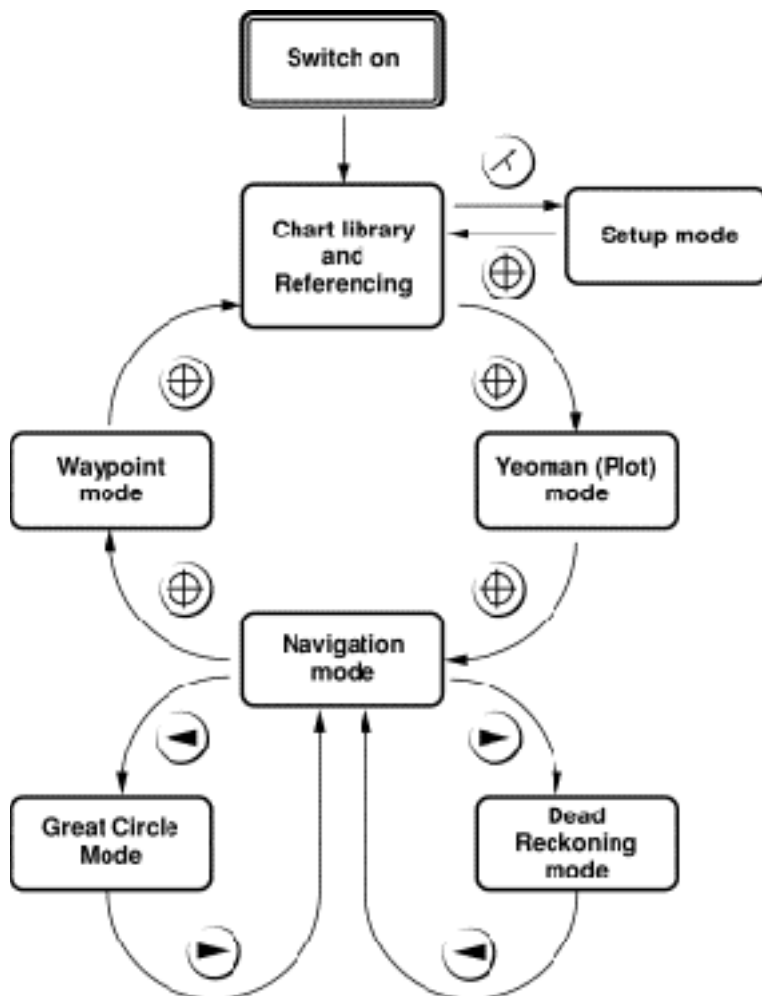

## 2. Installation

### 2.1 General installation notes

The YEOMAN Navigator Pro requires a power supply of 12V DC. Application of overvoltage will blow an internal fuse which will require the unit to be returned to a service dealer. It is also advisable to fit a surge protective fuse into the 12V power connection.

The chart mat must not be cut or drilled.

The YEOMAN Mouse curly cable should not be cut or interfered with in any way.

No metal should be within 50mm of the chart mat in any direction.

The active area of the chart is approximately 50mm in from the edges. Indicator lights will flash when the Mouse is outside this area.

The YEOMAN is reverse polarity protected and is designed for negative earth systems. Connection to positive earth systems should only be made by qualified personnel.

Although the YEOMAN is marinised, it should be kept clean and dry.

## 2.2 Installation

### 2.2.1 YEOMAN Navigator Pro

Make the following connections:

WHITE	(A) input to YEOMAN from GPS
BLUE	(B) input to YEOMAN from GPS
GREEN	(A) output from YEOMAN to GPS
THIN BLACK	0 volts and (B) output from YEOMAN to GPS
RED	12 volts DC power
THICK BLACK	Connect to ground or 0 volts, optional (SCREEN)

For further information refer to Section 14.

### 2.2.2 YEOMAN GPS Navigator Pro

Make the following connections:

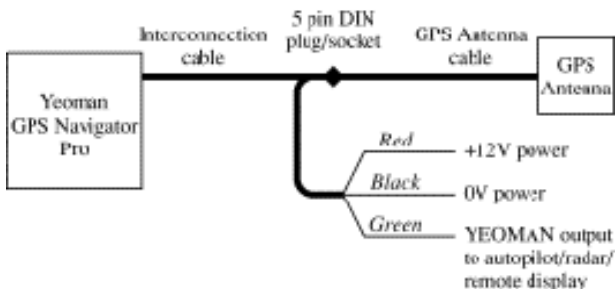

Mount the GPS antenna with its base horizontal and so that it has a clear view of the sky from horizon to horizon. The standard antenna is supplied in flush mount configuration - a pole mount kit is supplied which fits onto a standard 1" antenna mount. Connect the GPS antenna cable to the YEOMAN.

For further information refer to Section 14.

## 2.3 Power up and initial test

Apply power to the YEOMAN. The Mouse will emit an audible 'beep', the indicator lights will illuminate and text will appear on the display.

Lift the Mouse away from the chart mat and the indicator lights will flash, put the Mouse on the centre of the chart mat and all lights will stay on. This shows that the YEOMAN is functioning correctly and is ready for use.

### 3. Demonstration mode

All you need to get YEOMAN going is 12 volts DC.

A self-demonstrator is supplied to help gain familiarity with YEOMAN. This is set automatically when shipped and uses the practice chart packed with the Yeoman.

After power on, place the Mouse Plot Spot over the point marked "REF 1", and press . Repeat for points 2 and 3.

The YEOMAN will now enter YEOMAN mode and most functions of the YEOMAN may be used. In Navigation mode a simulated position and velocity allows familiarity to be gained.

The YEOMAN will exit Demonstration mode the first time that you reference a real chart. Section 11.1 describes how to re-enter demonstration mode.

When Demonstration mode is set, then the supplied practice chart must be used and the four red indicator lights will flash together every 10 seconds in all YEOMAN modes.

## 4. Basic Operations

### 4.1 Keypad

The YEOMAN uses the four arrow keys (▲) (▼) (▶) (◀) to enter numeric data such as Chart and Waypoint numbers, latitude and longitude.

#### 4.1.1 Entering Chart and Numbers

When selecting any of these numbers, the right hand digit will flash, indicating that you can enter or change a number.

For example, to enter the chart number 34:



S004

Press (▲). The flashing digit will increase by 1. If you press and hold (▲), the number will increment until it reaches 9, and then start counting again from 0. The (▼) key reduces the flashing digit by 1.

Press  until the display reads:

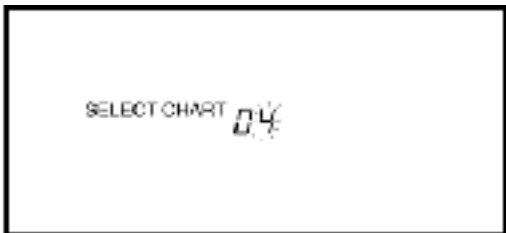

S005

Press . The left hand digit will start to flash.



S006

Press  to change the number to 3.

When the correct number is displayed, press  to accept.

### 4.1.2 Entering latitude and longitude

Latitude and longitude are entered and displayed in degrees, minutes and decimal minutes (2 places).

When a latitude and longitude need to be entered, the first digit of latitude will flash.



Enter the latitude using the  $\uparrow$   $\downarrow$  and  $\leftarrow$   $\rightarrow$  keys. Use  $\rightarrow$  to set N/S flashing then use  $\uparrow$  to toggle as required.

Press  $\rightarrow$  until the first digit of longitude is flashing.

Enter the longitude using the  $\uparrow$   $\downarrow$  and  $\leftarrow$   $\rightarrow$  keys.

To enter a longitude with degrees greater than 99° press  $\downarrow$  when the leftmost zero is flashing.

Use  $\rightarrow$  to set E/W flashing then use  $\uparrow$  to toggle as required.

Press  $\odot$  to confirm and enter the numbers.

### 4.2 Magnetic/True headings

All bearings are normally displayed as magnetic. The Setup section 11.1 describes how to change this to true.

### 4.3 Default hemispheres

The default hemisphere for entry of all latitude and longitude is determined by that set in reference position 1 of User Chart 00.

## 5. Chart library and referencing

Before using YEOMAN, a chart must be entered into the CHART LIBRARY and referenced. This requires the entry of the latitude and longitude of three positions on the grid intersections as below. The positions should be as far apart as practicable and marked clearly.

**THE LATITUDE OF POSITION 2 MUST BE THE SAME AS THAT OF POSITION 1. THE LONGITUDE OF POSITION 3 MUST BE THE SAME AS THAT OF POSITION 2.**

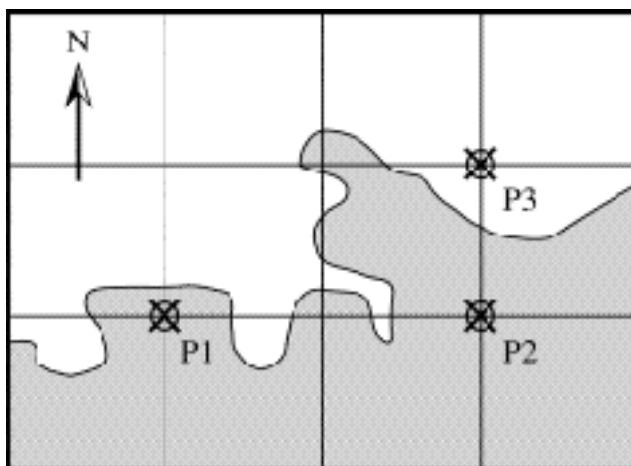

**IF THE CHART MOVES ON THE CHART MAT AFTER REFERENCING IT MUST BE RE-REFERENCED.**

Position 1 and Position 2 must be further than 50mm apart.

It is possible to reference a chart with only two reference positions and this is described in Section 11.5.

For units shipped in the USA with the ChartKit® library then Positions 1, 2 and 3 are replaced by Positions A, B and C.

Should a chart need to be overwritten at any stage, in chart select mode hold down  for six beeps. The position entry facility is displayed and the latitude and longitude of the positions can be altered.

YEOMAN can be used with any general chart providing that first three reference points are entered as in 5.1 below. Once entered these points are stored and build a library of User Charts. The user Chart library consists of 5 sets of user entered Charts, each set contains up to 100 Charts giving a total storage of 500 user Charts.

Some chart publishers are adding special pre-plotted YEOMAN reference points to charts to make these even easier to use with YEOMAN, again entering these as in 5.1 below. Similarly, once entered these points are stored.

For some of these pre-plotted charts YEOMAN pre-load a library in the YEOMAN Navigator Pro. Details of which such pre-loaded charts are in your unit are contained in a supplementary card with this handbook.

If the chart you are using has pre-printed reference points and is in the list on the supplementary card then go to Section 5.2.

Otherwise follow the instructions below.

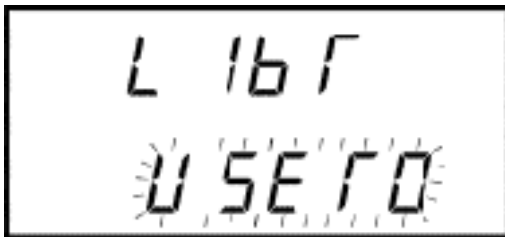

## 5.1 User chart library

The display should flash:







SO42

If not use   to get the display then accept with .

Use the   Keys to select a specific user library between 0 and 4. To move on from the user library to the pre-loaded library press the  key.

Select three reference points on the chart, mark them clearly, and number them P1, P2 and P3.

Allocate a user chart library number (00-99) and write it down along with its user library number on the edge of the chart for future reference. At the 'Select Chart' display, use the     keys to select the chart number.



S011

If you select a chart number which has already been used the display reads:



S008

Press  to accept the chart number.

The display then shows P1 (Position 1). The first digit of latitude will flash.





S007

Enter the latitude and longitude for P1, ensuring that N/S and E/W are entered correctly (see Section 4.1.2).

Press  to accept Position 1 (P1).

Enter the latitude and longitude for Position 2 (P2) and Position 3 (P3) in the same way.

If a mistake is made during the entry of any of the positions press  and then hold  down for six beeps. The display will revert back to the position entry facility where the latitude and longitude of the positions can be edited.

Now go direct to Section 5.3.

## 5.2 Pre-loaded chart library

Use  to get the display flashing the YEOMAN designation of the pre-loaded library that you wish to use. For instance for UK Admiralty Small Craft Edition scroll until

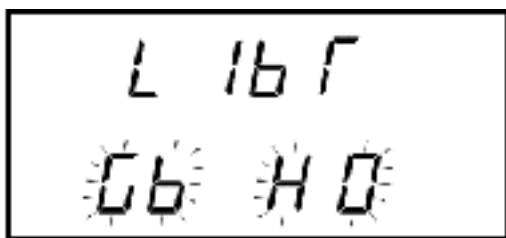

S043

is displayed flashing.

For ChartKit® library scroll until

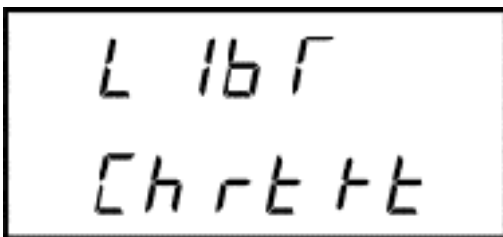

SO44

is displayed flashing.

Select the pre-loaded library with  $\odot$ .

Select the chart set required. For example with UK Admiralty charts select Folio 5600, 5604 etc. using  $\blacktriangle$ . For ChartKits®, select the Region using  $\blacktriangle$ .

Select chart number in series required (see Section 4.1.1).

### 5.3 Referencing the chart

The display will now read:



SO09

Align the Plot Spot over chart reference Position 1. Press  $\odot$ . Repeat action for Positions 2 and 3.

During referencing the latitude and longitude of the reference points can be displayed by pressing  $\blacktriangle$ .

If the chart has been referenced correctly the YEOMAN will advance to YEOMAN (PLOT) mode after Position 3 has been accepted. A quick check of the referencing should be made on a suitable point (such as another grid position) and the display should be compared with a chart position.

If the referencing has been done incorrectly the indicator arrows flash and the display shows:



S013

In this case there has been one of:

- Incorrect positioning of the Mouse or chart moved during referencing. Press ⊕ to return to chart referencing and then reference again carefully.

Or

- Incorrect or inconsistent latitude/longitude of one or more of the reference positions. Press ⊕ to return to chart referencing and re-reference, this time displaying the latitude and longitude of the reference points by using ▲, as described earlier. Specifically check N/S and E/W entries are correct and that P1 and P2 are more than 50mm apart.

Or

- One of the reference points is outside the active area. The indicator lights will flash when over the position. Select a new reference point or re-position chart.

Depending on the result either correct the reference position latitude and longitude as described earlier, or mark corrected reference positions on the chart.

## 6. YEOMAN (plot) mode

This mode is used for normal chart work and for obtaining range and bearing between points.

The YEOMAN goes to this mode when referencing is completed; or press ⊕ until YE appears on the display.



S014

The display will now indicate the latitude and longitude of the Plot Spot position as the Mouse is moved.

To memorise a chart position place the Plot Spot over it and press ●, the indicator arrows extinguish.

This action also outputs a 'GLL' position on the NMEA 0183 output line.

Press ⊖ to get Range and Bearing to anywhere on the chart the Mouse is placed from the memorised position.

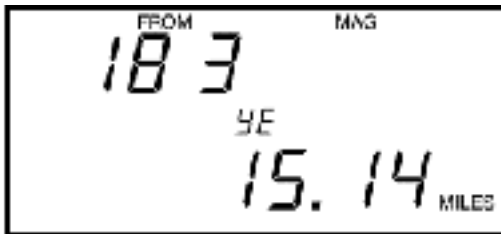

S015

Toggle to the reciprocal bearing by pressing ▼. Holding down the ▲ displays temporarily the reciprocal bearing.

Press ⊖ to return to latitude/longitude display. The illuminated arrows will show the direction to the memorised point.

## 7. Navigation mode

This mode allows the current position from a GPS to be plotted directly on to the chart. Scroll with  $\oplus$  to Navigation (NA) mode.

If the indicator arrows flash the YEOMAN is not receiving valid data from the GPS. Refer to Section 14.

The latitude and longitude of the GPS position is displayed, and is updated every few seconds.

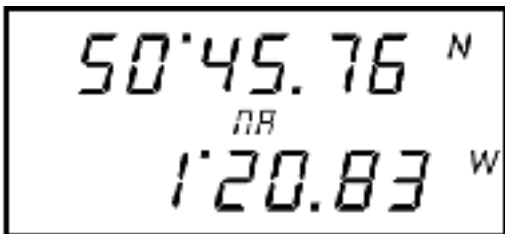

S017

One or two of the indicator arrows will illuminate and point to the position on the chart. Move the Mouse in the direction the arrows indicate until they are all extinguished. The Plot Spot is now over the GPS position, and this can be plotted using a pencil through the Plot Spot hole.

Press  $\odot$  to get Range and Bearing to anywhere on the chart the Mouse is placed from the current GPS position in a similar way to that in YEOMAN mode.

Press  $\blacktriangle$  to display Course over Ground (CO) and Speed over Ground (SP), in knots, from the GPS.



S018

Press  $\uparrow$  to display Time to Go (tt GO). This will show the time to go in hours and minutes from ship's position to the Plot Spot at the current speed over ground. The calculation does not take into account the current course.

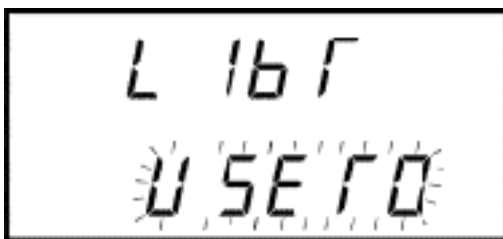

S019

## 7.1 Integral GPS (YEOMAN GPS Navigator Pro only)

All GPS information is displayed in the (NA) Navigation page. If no fresh GPS data is available, then the last good position will be shown and all indicator lights will flash.

Pressing the  $\downarrow$  key will then display the first GPS display page:

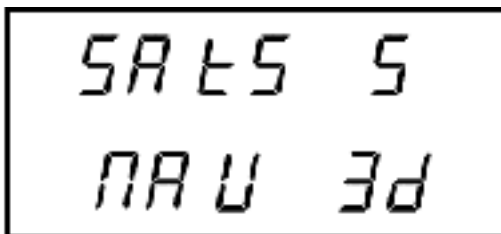

S020

The upper line indicates the number of satellites currently in view. This will normally be zero or a small number when the unit is first turned on and then increases as satellites are found.

If the upper line shows '-' then this indicates that no data is being received from the GPS antenna. Check all connections and if necessary contact a service dealer. If a zero or any other number is shown then this indicates that data is being received.

The lower line shows the mode of navigation. 0d indicates no fix available while two and three dimensional fixing are indicated by 2d and 3d respectively.

The second GPS page is accessed with a further press of the  key:

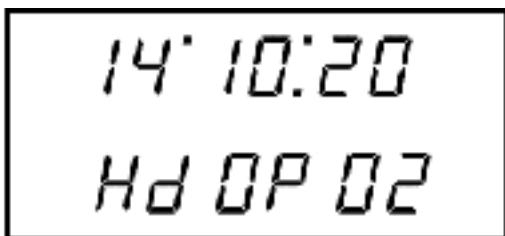

S021

Now the first line shows GPS time in Universal Time (effectively GMT).

The lower line shows the Horizontal Dilution of Position (1-99) which is a measure of quality of fix (lower number means higher geometric quality).

Pressing  twice steps back through the first GPS page to the Navigation display.

## 8. Waypoint mode

Waypoints can be entered directly from the chart, or manually using the Mouse keys. The YEOMAN will also send the Waypoint information to a GPS receiver.

Press  $\oplus$  to scroll to WAYPOINT mode.

The current Waypoint number will be displayed.

Select the Waypoint position on the chart and allocate a number (000-499) from the Waypoint Library. Mark the Waypoint on the chart and write the number beside it in pencil.



Set the Waypoint number using  $\uparrow$   $\downarrow$   $\rightarrow$   $\leftarrow$ . Only the last two digits of the Waypoint number will show on the display, shifting to either the right or left of the visible digits with  $\rightarrow$  OR  $\leftarrow$  will display



and allow the complete Waypoint number to be entered. Once the hundreds are set between 0 and 4 this remains in force until changed.

Place the plot spot on the Waypoint position on the chart and press  $\odot$  to enter into the Waypoint library. The indicator arrows extinguish and the latitude and longitude of the Waypoint position are displayed.

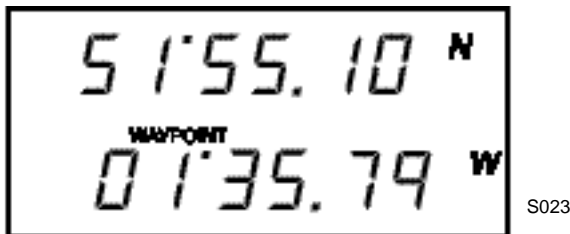



When the Mouse is moved, one or two indicator arrows will illuminate and point to the Waypoint position on the chart.

Waypoints already stored are overwritten if a new position is entered using the same number. If an existing Waypoint is accessed, its position will appear on the display and the indicator arrows will show its position. Consequently a Waypoint stored in the Waypoint library can be transferred from chart to chart.

Press  to get Range and Bearing to anywhere on the chart the Mouse is placed from the current Waypoint position in a similar way to that in YEOMAN mode.

## 8.1 Manual Waypoint entry

To manually enter a Waypoint set the Waypoint number then press  and hold down for six beeps. Set in the latitude and longitude of the Waypoint, as in Section 4.1.2. Press  to accept Waypoint.

## 8.2 Sending Waypoints to a GPS

### 8.2.1 General

When a Waypoint is entered into the YEOMAN its number and position is transmitted to the GPS via the NMEA 0183 output. A GPS with a suitable NMEA 0183 input capability will be able to accept the Waypoints directly from the YEOMAN.

## 8.2.2 Special considerations

There are a few important points to consider when sending Waypoints to a GPS and some checks are worthwhile:

- Is the GPS capable of receiving Waypoints from another piece of equipment? Does it have an input port and, if so, does it accept the correct data? Please consult your GPS handbook, your dealer or YEOMAN.
- Are the connections correct? Refer to Section 14.
- Some GPS allow their Waypoints to be overwritten - in the same way as YEOMAN does, and some do not.
- Some GPS do not change the displayed Waypoint on entry from YEOMAN. Scroll the GPS display away from Waypoint entered and then scroll back to view the new Waypoint position.
- Waypoint 000 is never transmitted.

## 8.3 Autopilot output (YEOMAN GPS Navigator Pro only)

Provided that the YEOMAN GPS Navigator Pro is receiving position then output is sent out to drive an autopilot.

To do this set or select an end Waypoint with any number except 000. Once this destination Waypoint is selected, then use the ⊕ key to move on from the Waypoint page. At this point the run-line to be followed is set between the current GPS position and the selected destination Waypoint. Autopilot information will then start to be transmitted while the GPS is still obtaining a valid fix.

Once started, autopilot data will be sent and stopped only by:

1. GPS loss of signal. Autopilot data will cease, but resume when GPS signal is re-acquired, subject to other conditions below.
2. Reaching the destination Waypoint in the sense shown in the diagram below:

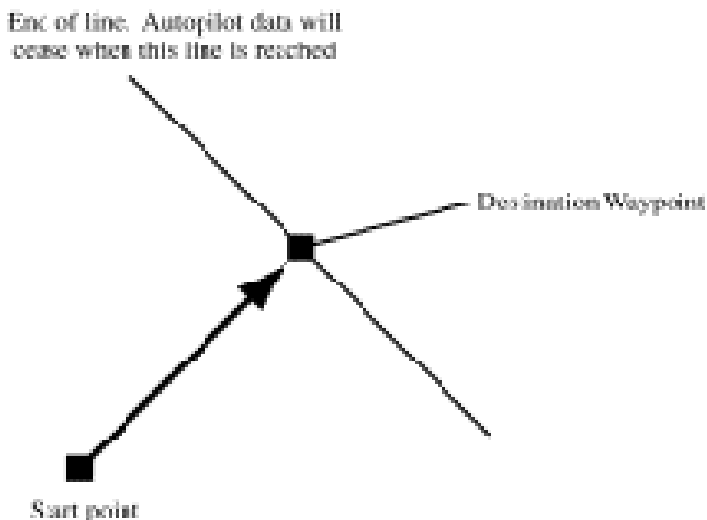

3. Selecting Waypoint 000.
  4. Turning unit off then on again, destination Waypoint will be preserved, but must be reactivated by selecting Waypoint page and moving on past it again using the ⊕ key.
- If a 'null' Waypoint is selected then autopilot information will continue to be transmitted to the last valid Waypoint selected.

When valid autopilot data is being transmitted then the Navigation (NA) and YEOMAN (YE) display pages will have the WAYPOINT flag in the centre of the LCD display showing.

On the Waypoint page, it is possible to scroll through and enter Waypoints other than the current destination Waypoint without disturbing the autopilot output. The TO flag on the upper edge of the LCD display will show on the destination Waypoint only.

If the position of the current destination Waypoint is changed, then the output to the autopilot changes immediately to the new position from current GPS position. This gives the powerful 'point and go' method of driving an autopilot. If a Waypoint other than the current destination is selected when the Waypoint page is left then this new point will become the destination, starting from the current GPS position.

No facility for holding routes is provided. When a Waypoint is reached, select the next point by setting the Waypoint either from the library or by putting the Mouse over next destination point and updating current Waypoint by pressing .

To disable output select Waypoint 000.

There is no display of cross-track offset as this can very simply be picked off the chart using the normal YEOMAN plotting facilities.

## 9. Dead reckoning

This mode allows for the calculation and plotting of position by Dead Reckoning (DR).

If the Tidal Direction and Rate are input as well as Course and Speed then these will be included in the calculation in order to enable an Estimated Position (EP) to be plotted.

Scroll with  $\oplus$  to NA mode and press  $\rightarrow$  to DR Mode. Place the Plot Spot on ship's current position on the chart and press  $\odot$ . The latitude and longitude of the position are displayed.

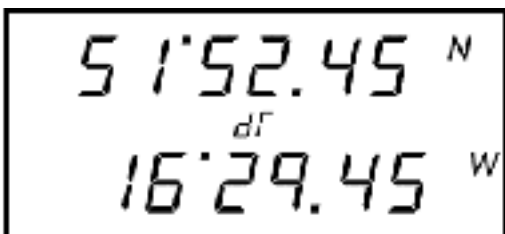

S025

YEOMAN will update this and the DR position can be plotted using the indicator arrows, as in the NA mode. Refer to Section 7.

To set DR Course, Speed and Tidal data press  $\oplus$ . To exit DR mode press  $\rightarrow$ . The display shows:

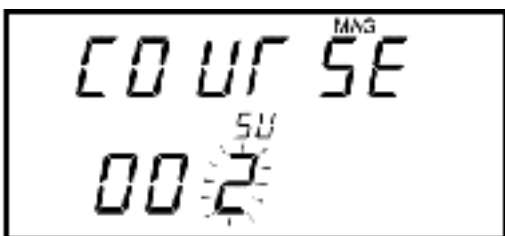

S026

Using  $\rightarrow$   $\leftarrow$   $\uparrow$   $\downarrow$  set course. Press  $\odot$  to accept.

If there is an NMEA 0183 sentence "VHW" from the compass and log then course and speed will automatically up-date. Display shows:



S027

Using  $\uparrow$   $\downarrow$   $\rightarrow$   $\leftarrow$  set speed. Press  $\bullet$  to accept. The display shows:



S028

Using  $\uparrow$   $\downarrow$   $\rightarrow$   $\leftarrow$  set water current direction and velocity. Press  $\bullet$  to accept.

Press  $\oplus$  to return to DR mode and then press  $\rightarrow$  to exit DR mode and return to NA mode.

At any time DR/EP position can be updated by placing the Plot Spot over an updated fixed position and pressing  $\bullet$  while in DR mode.

## 10. RADAR functions

### 10.1 Overview

A number of small boat RADARs have a feature which displays as a 'lollipop' the next Waypoint in a sailplan from a GPS. These RADARs can, in general, also be connected to the Navigator Pro. The general arrangement of the connections is shown below:

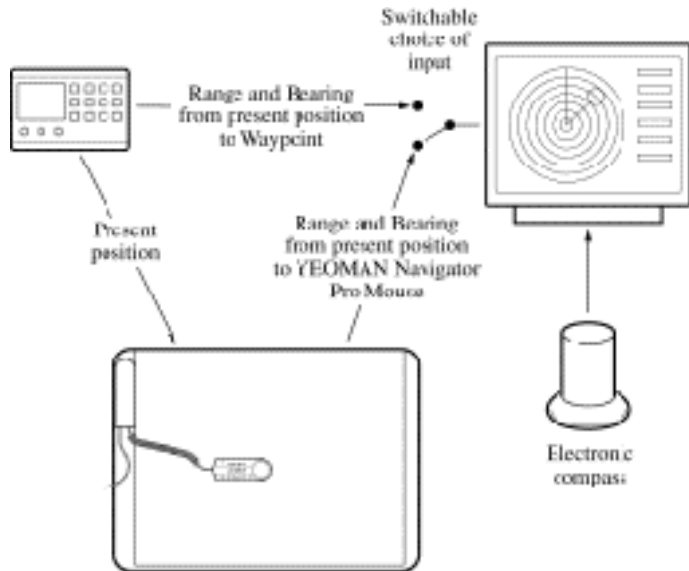



To use YEOMAN input and GPS input a changeover switch is needed as the RADAR cannot accept two inputs at the same time. Such a switch (DATABOX) is available from YEOMAN or can be made as in Section 14.3.

When the RADAR input is set to the YEOMAN, the 'lollipop' on the RADAR will track the position of the YEOMAN mouse on the chart, see Section 10.2 below. An electronic compass input is needed for the RADAR to enable this. Note that Course Over the Ground input from a GPS cannot be used in the place of a compass.

## 10.2 RADAR plotting

Set the YEOMAN into Navigation Mode, see Section 7, and then display range/bearing using the  key and then:

- Press the  key once to send a snap-shot of the Mouse position to the RADAR. Note that this does not automatically update. Further presses of the  key are needed to update new range and bearing to the RADAR.
- Alternatively, hold the  key down for five beeps and then release it. The YEOMAN then streams range/bearing data to the RADAR continuously from the Mouse position wherever it is moved. There may be a slight delay in the response of the RADAR 'lollipop', which varies with RADAR model and manufacturer.

As soon as range/bearing display is changed, then output to the RADAR ceases. A short period later the RADAR 'lollipop' display will then disappear and 'no data' may be flashed (dependent on RADAR used).

RADAR plotting will also function in a similar way from DR mode, see Section 9.

The YEOMAN RADAR plotting system does nothing more nor less than replicate a manual plot, with the exception of being easier, quicker and less prone to manual plotting error. The sources of error are thus the same and fall into the following categories:

### **RADAR misalignment**

Common to manual or YEOMAN plotting. See RADAR handbook or any book on RADAR for techniques on how to resolve and rectify this.

### **Compass misalignment or calibration error**

Potentially an area where manual plotting, probably using the main steering compass, and YEOMAN plotting, based on the RADAR's electronic compass, may differ.

A careful check of the electronic compass used for the RADAR against a properly swung primary compass, taking account of the deviation card, should be made on all compass headings.

This should be checked from time to time, especially after any refit, in case the electronic compass sensor should have been disturbed or any change to its magnetic environment occurred (e.g. electrical equipment or magnetic material placed nearby).

### **Navigation system error**

Common to either methods and the user should always remain alert to the fact that the electronic position data may be in error or may not tie up to the co-ordinates on the chart. Remedies include:

- a second independent electronic navigation system (i.e. use both GPS and DECCA or LORAN) and compare regularly
- regular checking against conventional navigation including dead reckoning, depth sounder and compass bearings on known features
- checking against RADAR, for which the YEOMAN plotting system is particularly convenient.

## Plotting position error

Both manual and YEOMAN position plotting can be checked by the same methods as above. The likeliest form of error with the YEOMAN is movement of the chart since it was last referenced. If in any doubt it is sensible to re-reference, which takes but a few seconds, before plotting.

It is suggested that after initial installation, a careful check against a manual plot and known scenario (e.g. vessel held in marina berth with well identified RADAR targets such as channel markers). Regular checks against well identified targets in good conditions will assist both with functional familiarity and with confidence and reliability assessment when needed under more testing conditions.

## 10.3 RADAR troubleshooting

If the RADAR 'lollipop' cannot be initiated by setting the YEOMAN into RADAR plotting mode, a suggested list of symptoms and tests is given below:

- a) Ensure that RADAR is receiving compass data and is set in magnetic compass 'mode'. The RADAR will not accept range/bearing data and plot the 'lollipop' otherwise. Check the compass and interfacing to the RADAR.
- b) If the RADAR is accepting compass data then remaining areas to check are-

selection of Waypoint plotting mode on RADAR, see manufacturer's handbook

interfacing to the RADAR. Check this by linking the GPS directly to the RADAR to see if conventional GPS RADAR Waypoint plotting is working.

## 11. Advanced features

### 11.1 Setup mode

Press the ⊕ button repeatedly until you get to Chart Referencing mode. Press ↵ to enter Setup mode. Press ⏪ to step between setup screens in the following order:

- GPS Datum (YEOMAN GPS Navigator Pro only)
- Year
- True/Magnetic selection
- Clear Waypoints
- GPS interface
- Waypoint prefix
- Demonstration mode selection.





#### 11.1.1 GPS datum (YEOMAN GPS Navigator Pro only)



S041

This shows that the GPS Datum is number 100 (WGS 84). You can change the Datum using the ⏩ and ⏪ buttons. Refer to Section 13 for a list of datum code numbers.

### 11.1.2 Year

Use the     keys to enter the current year.

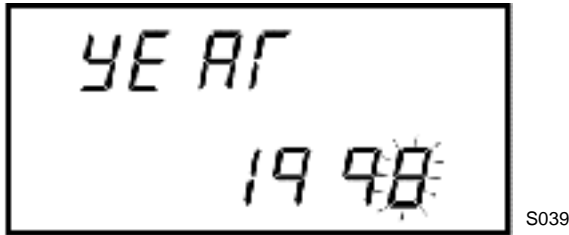



This is used to calculate magnetic variation.

### 11.1.3 True/Magnetic selection

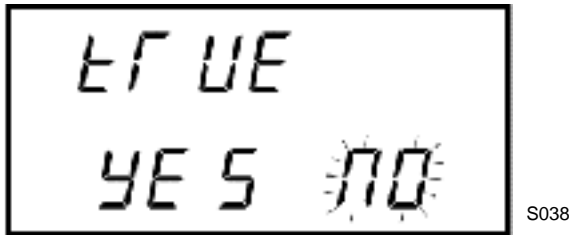
This option lets you change the heading definition.



Yes or No can be selected using the  or  keys.

YES tells the YEOMAN to use True headings.

NO selects automatic magnetic variation.

Press  to enter your choice.

### 11.1.4 Clear Waypoints

This option clears ALL Waypoints stored within the YEOMAN memory.



To clear the Waypoints, press  $\rightarrow$  to select Yes, and then press  $\odot$ . Otherwise, select No and press  $\odot$ .

### 11.1.5 GPS interface

The default GPS interface works with the majority of GPS receivers. This function selects for specific GPS units.



- 00 Default, Standard NMEA 0183 - suits most receivers
- 01 Magellan 3000 XL
- 02 MLR Valsat SP
- 03 MLR Valsat 2008
- 04 Trimble NT series

Additional information on GPS types may be on a card packed with the handbook.

### 11.1.6 Demonstration mode selection

The display will show:

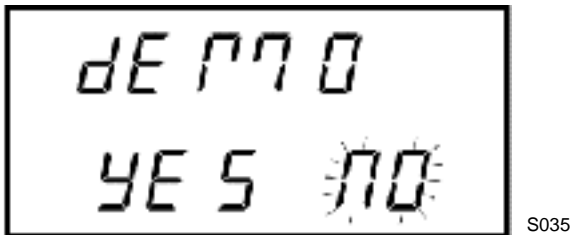

Select Yes or No using  $\rightarrow$   $\leftarrow$  then press  $\odot$ .

When Demonstration mode is set then the supplied practice chart must be used and the four red indicator lights will flash together every 10 seconds in all YEOMAN modes.

### 11.2 Memory Reset

This function resets the YEOMAN to its factory defaults.



ALL INFORMATION YOU HAVE INPUT WILL BE LOST, INCLUDING CHARTS AND WAYPOINTS. THE PRE-LOADED CHART LIBRARY WILL NOT BE DELETED.

To reset the YEOMAN to its factory defaults, hold down  $\downarrow$  and switch on the power. Keep the key depressed until the display reads:



Press  $\rightarrow$  to select Yes, and then press  $\odot$ . Turn the power off again. When you next turn the power on the unit will have been reset to its factory defaults.



## 11.3 Freeze Mode

It is possible to freeze the display while operating the Range and Bearing facility by holding down  for five beeps. This allows the Mouse to be picked up and the display read without alteration. To unfreeze the display press .

## 11.4 Lock mode

Whilst in Navigation mode, pressing  for two beeps locks the YEOMAN in Navigation mode, while still allowing different modes such as Satellite Info, Range and Bearing, manual Dead Reckoning, Course, Speed Over Ground and Time To Go to be accessed.

When in Lock mode the NA flag in the centre of the screen changes to NL.

Press  for one beep or a single press of  unlocks the lock mode.

## 11.5 Two position referencing

The YEOMAN will operate with only two reference positions by referencing Positions 1 and 2 normally and then by referencing Position 3 on the same point as Position 2.

This method of chart referencing allows the use of small charts and insets where it might be difficult to find three suitable reference positions. It also enables the creation of a large scale Mercator plotting sheet.

REFERENCING ON TWO POSITIONS PROVIDES NO REFERENCING CHECK AND MAY RESULT IN SMALL INACCURACIES. USE THIS METHOD WITH CAUTION.

## 11.6 Great circle navigation

The shortest distance between two points on the earth's surface is a circle whose plane passes through the earth's centre. This is referred to as a Great Circle (GC). On a Mercator chart this appears as a curve.

In practice there is not a significant difference in length between the conventional Rhumb Line and a Great Circle for points less than 600 miles apart. It is for this reason that Great Circle Sailing is normally only used for trans-oceanic passages.

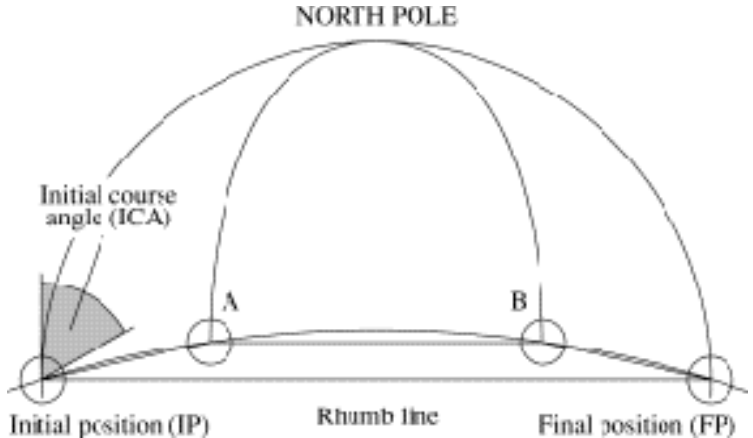

In practice it is not possible to steer in a gradual circle so the GC is split into a series of Rhumb lines between positions selected to be about a day's run apart. In the figure, A & B are two such positions. By defining these intervening positions and then entering them together with the final position as sequential Waypoints in the Waypoint mode, a route or sailplan can be plotted for an ocean passage.

Scroll  $\oplus$  to NA mode and press  $\rightarrow$  to GC mode. The display shows

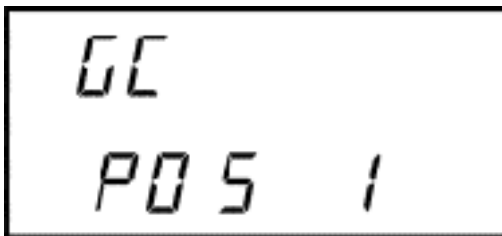

SO45

Place Plot Spot over initial position (IP). Press  $\odot$  to enter IP.

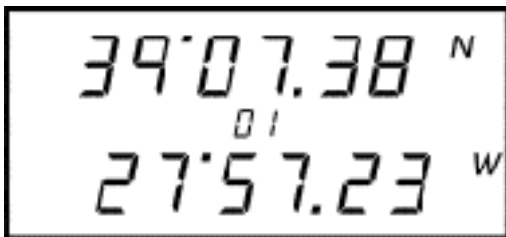

S046

(off Graciosa in the Azores).

Place Plot Spot over Final Position (FP). Press  to enter FP.

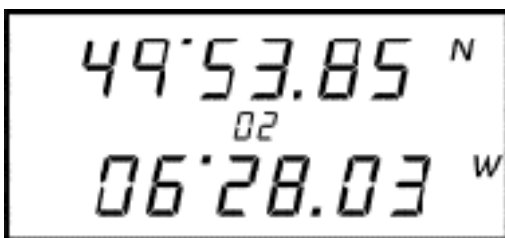

S047

(off Bishop Rock - Scilly Is).

Press  again and Initial Course, Angle and Distance are displayed.

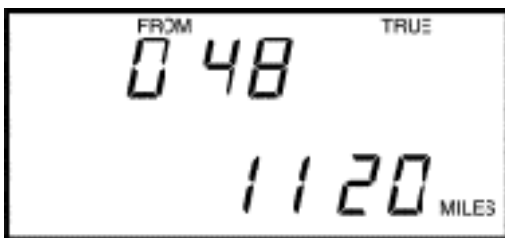

S048

Press  $\odot$  again and place Plot Spot on an intermediate Longitude Meridian - say 20 degrees W. The Latitude at which the GC crosses 20 degrees W is displayed.

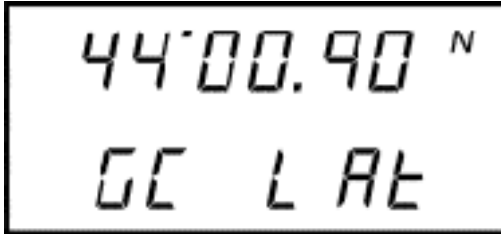

S049

Giving an intermediate Waypoint of

44° 00.90' N

20° 00.00' W

Only the North and South indicator arrows are operative, pointing to the direction in which the Puck must be moved up or down the meridian to coincide with the GC Waypoint. Repeat for each intermediate Waypoint.

Press  $\rightarrow$  to return to NA mode. This retains the current GC in memory to allow the user to change charts if required. If, on re-entry to GC mode the GC Pos 1 display is not showing a further press of the  $\rightarrow$  will allow entry of a new GC.

### 11.6.1 Manual entry

Follow previous instructions until display shows:-

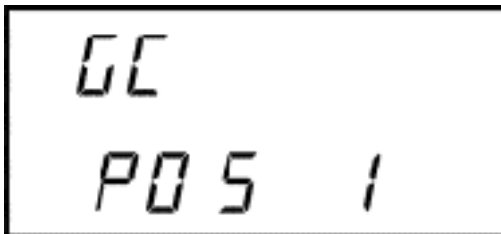





SO45

Press  $\odot$  and hold down for 6 beeps. The last IP is now displayed.



SO50

Use    keys to enter new initial position. Press  to enter IP.

Similarly enter the final position (FP) other functions are as described earlier.

## 12. Troubleshooting

<b>Problem</b>	<b>Possible cause</b>	<b>Suggested action</b>
NO RESPONSE. NO DISPLAY OR BACKLIGHT.	A) No external power supply. B) Blown internal fuse.	A) Check battery voltage. Check polarity (red +12V, thin black 0V) Check any external fuse. B) Return to service dealer.
UNIT COMES ON AND THEN SCREEN BLANKS OR LOCKS UP.	A) Low voltage or corrupted data being transmitted to YEOMAN.	A) Check battery voltage. Temporarily disconnect input data cable.
YEOMAN DOES NOT REFERENCE CORRECTLY.	A) Incorrect reference positions. B) Reference positions outside active area. C) Reference positions too close.	A) Check Lat/Long of reference positions. B) Check positions are within the active area of the chart table. C) Check P1 and P2 are more than 50mm apart.
YEOMAN NAVIGATOR PRO PLOTS INACCURATE POSITION.	A) Unit corrupted by metal. B) Chart has moved. C) GPS input is defective.	A) Check that there is no metal near YEOMAN Navigator Pro. B) Fix chart and re-reference. C) Check connections, interface and Datum are correct.
YEOMAN LIGHTS FLASH IN NAVIGATION MODE.	A) YEOMAN not receiving position	A) Check GPS specification. Check connections.
YEOMAN DOES NOT RETAIN REFERENCE POSITIONS.	A) Internal battery flat	A) Return to service dealer or YEOMAN.
YEOMAN LIGHTS FLASH AT TEN SECOND INTERVALS.	A) In Demo mode	A) See Section 3 and 11.1.7.

## 13. Datum list

INDEX	DATUM EARTH NAME	AREA OF APPLICATION
0	ADINDAN	Ethiopia, Mali, Senegal, Sudan
1	AFGOOYE	Somalia
2	AIN EL ABD 1970	Bahrain island, Saudi Arabia
3	ANNA 1 ASTRO 1965	Cocos Island
4	ARC 1950	Botswana, Lesotho, Malawi, Swaziland, Zaire, Zambia, Zimbabwe
5	ARC 1960	Kenya, Tanzania
6	ASCENSION ISLAND 1958	Ascension Island
7	ASTRO BEACON "E"	Iwo Jima Island
8	AUSTRALIAN GEODETIC 1966	Australia, Tasmania Island
9	AUSTRALIAN GEODETIC 1984	Australia, Tasmania Island
10	ASTRO DOS 71/4	St Helena Island
11	ASTRONOMIC STATION 1952	Marcus Island
12	ASTRO B4 SOROL ATOLL	Tern Island
13	BELLEVUE (IGN)	Efate and Erromango Islands
14	BERMUDA 1957	Bermuda Islands
15	BOGOTA OBSERVATORY	Colombia
16	CAMPO INCHAUSPE	Argentina
17	CANTON ASTRO 1966	Phoenix Islands
18	CAPE CANAVERAL	Florida, Bahama Islands
19	CAPE	South Africa
20	CARTHAGE	Tunisia
21	CHATHAM 1971	Chatham Island (New Zealand)
22	CHUA ASTRO	Paraguay
23	CORREGO ALEGRE	Brazil
24	DJAKARTA (BATAVIA)	Sumatra Island (Indonesia)
25	DOS 1968	Gizo Island (New Georgia Islands)
26	EASTER ISLAND 1967	Easter Island
27	EUROPEAN 1950	Austria, Belgium, Denmark, Finland, France, Germany, Gibraltar, Italy, Greece, Luxembourg, Netherlands, Norway, Portugal, Spain, Sweden, Switzerland
28	EUROPEAN 1979	Austria, Finland, Netherlands, Norway, Spain, Sweden, Switzerland
29	FINLAND HAYFORD 1910	Finland
30	GANDAJIKA BASE	Republic of Maldives
31	GEODETIC DATUM 1949	New Zealand
32	ORDNANCE SURVEY OF GREAT BRITAIN 1936	England, Isle of Man, Scotland, Shetland Islands, Wales
33	GUAM 1963	Guam Island

34	GUX 1 ASTRO	Guadalcanal Island
35	HJORSEY 1955	Iceland
36	HONG KONG 1963	Hong Kong
37	INDIAN	Bangladesh, India, Nepal
38	INDIAN	Thailand, Vietnam
39	IRELAND 1965	Ireland
40	ISTS 073 ASTRO 1969	Diego Garcia
41	JOHNSTON ISLAND 1961	Johnston Island
42	KANDAWALA	Sri Lanka
43	KERGUELEN ISLAND	Kerguelen Island
44	KERTAU 1948	West Malaysia, Singapore
45	LC 5 ASTRO	Cayman Brac Island
46	LIBERIA 1964	Liberia
47	LUZON	Mindanao Island
48	LUZON	Phillippines (excluding Mindanao Island)
49	MAHE 1971	Mahe Island
50	MARCO ASTRO	Salvage Islands
51	MASSAWA	Eritrea (Ethiopia)
52	MERCHICH	Morocco
53	MIDWAY ASTRO 1961	Midway Island
54	MINNA	Nigeria
55	NORTH AMERICAN 1927	Alaska
56	NORTH AMERICAN 1927	Bahamas (excluding San Salvador Island)
57	NORTH AMERICAN 1927	Central America (Belize, Costa Rica, El Salvador, Guatemala, Honduras, Nicaragua)
58	NORTH AMERICAN 1927	Canal Zone
59	NORTH AMERICAN 1927	Canada (including Newfoundland Island)
60	NORTH AMERICAN 1927	Caribbean (Barbados, Caicos Islands, Cuba, Dominican Republic, Grand Cayman, Jamaica, Leeward Islands, Turks Islands)
61	NORTH AMERICAN 1927	Mean Value (CONUS)
62	NORTH AMERICAN 1927	Cuba
63	NORTH AMERICAN 1927	Greenland (Hayes Peninsula)
64	NORTH AMERICAN 1927	Mexico
65	NORTH AMERICAN 1927	San Salvador Island
66	NORTH AMERICAN 1983	Alaska, Canada, Central America, CONUS, Mexico
67	NAPARIMA, BWI	Trinidad and Tobago
68	NAHRWAN	Masirah Island (Oman)
69	NAHRWAN	Saudi Arabia
70	NAHRWAN	United Arab Emirates
71	OBSERVATORIO 1966	Corvo and Flores islands (Azores)
72	OLD EGYPTIAN	Egypt

73	OLD HAWAIIAN	Mean Value
74	OMAN	Oman
75	PICO DE LAS NIEVES	Canary Islands
76	PITCAIRN ASTRO 1967	Pitcairn Island
77	PUERTO RICO	Puerto Rico, Virgin Islands
78	QATAR NATIONAL	Qatar
79	QORNOQ	South Greenland
80	REUNION	Mascarene Island
81	ROME 1940	Sardinia Island
82	RT 90	Sweden
83	PROVISIONAL SOUTH AMERICAN 1956	Bolivia, Chile, Colombia, Ecuador, Guyana, Peru, Venezuela
84	SOUTH AMERICAN 1969	Argentina, Bolivia, Brazil, Chile, Colombia, Ecuador, Guyana, Paraguay, Peru, Venezuela, Trinidad, Tobago
85	SOUTH ASIA	Singapore
86	PROVISIONAL SOUTH CHILEAN 1963	South Chile
87	SANTO (DOS)	Espirito Santo Island
88	SAO BRAZ	Sao Miguel, Santa Maria Islands (Azores)
89	SAPPER HILL 1943	East Falkland Island
90	SCHWARZECK	Namibia
91	SOUTHEAST BASE	Porto Santo and Madeira Islands
92	SOUTHWEST BASE	Faial, Graciosa, Pico, Sao Jorge, and Terceira Islands (Azores)
93	TIMBALAI 1948	Brunei and East Malaysia (Sarawak and Sabah)
94	TOKYO	Japan, Korea, Okinawa
95	TRISTAN ASTRO 1968	Tristan da Cunha
96	NOT USED	
97	VITI LEVU 1916	Viti Levu Island (Fiji Islands)
98	WAKE-ENIWETOK 1960	Marshall Islands
99	WORLD GEODETIC SYSTEM 1972	
100	WORLD GEODETIC SYSTEM 1984	<b>System default</b>
101	ZANDERIJ	Surinam
102	CH-1903	Switzerland
103	HU-TZU-SHAN	
104	INDONESIA 1974	Indonesia
105	AUSTRIA	Austria
106	POTSDAM	Germany
107	TAIWAN (MODIFIED HU-TZU-SHAN)	Taiwan

## 14. Interfacing details

Interfacing uses standard NMEA 0183 sentences. Some manufacturers have introduced variants which require a setting as in Section 11.1.5.

Details of connections to sample GPS units are at the end of this Handbook. Datasheets on most GPS and other units are held by YEOMAN and available from them, a dealer or the YEOMAN website.

### 14.1 YEOMAN Navigator Pro connections

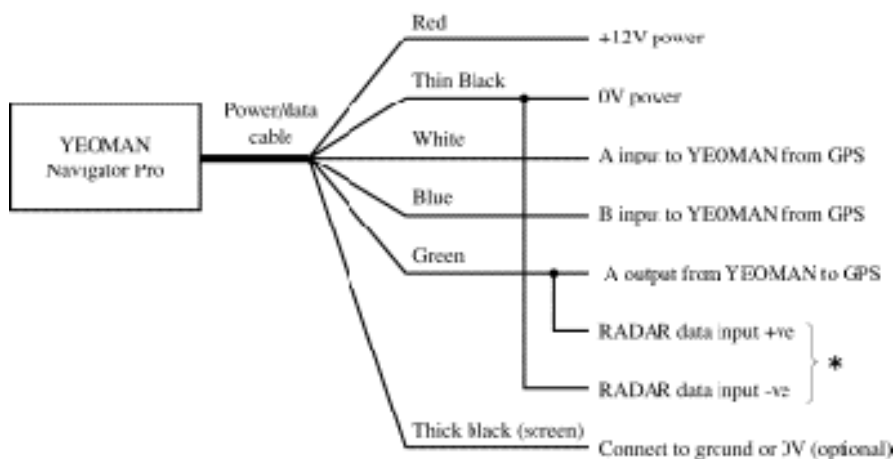

\* Only if RADAR plotting required - see 10.2

If the GPS has a two wire output, i.e. Data out A (or +) and Data out B (or -) then connect Data out A to the YEOMAN White and Data out B to the YEOMAN blue.

If the GPS has a single wire output (Data out) then connect this to the YEOMAN white. The YEOMAN blue is in these cases connected to 0 volts i.e., the same point as the YEOMAN thin black.

If the GPS has a two wire input, i.e. Data In A (or +) and Data In B (or -), then connect Data In A to the YEOMAN green. Data In B will need to be connected with a link wire to 0 volts i.e., the same point as the YEOMAN thin black.

If the GPS has a single wire input, (Data In) then connect this to the YEOMAN green.

## 14.2 YEOMAN GPS Navigator Pro

Standard connections are shown in Section 2.2.2. In order to connect a RADAR or autopilot it is necessary to break into the interconnect cable, which may be extended as necessary. The following diagram gives guidance on the connections; power input via the Power cable is not shown.

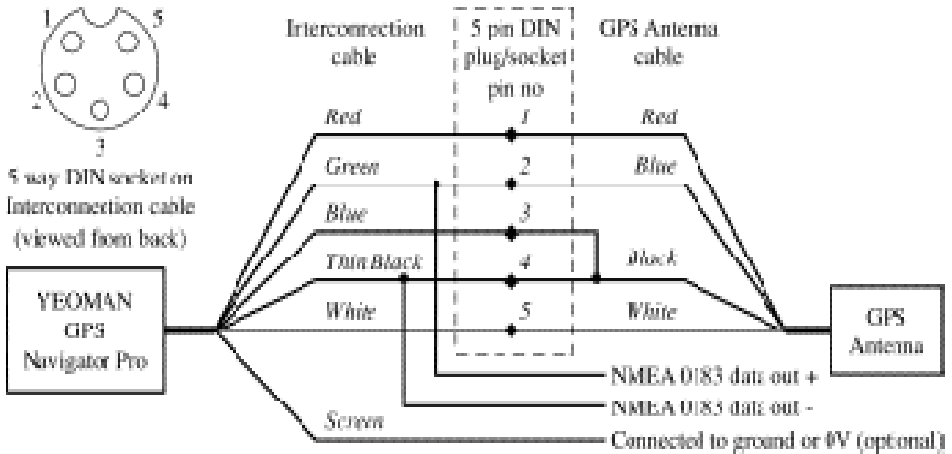

The NMEA 0183 data out can be connected either to an autopilot or to a RADAR.

### 14.3 RADAR data change-over switch

To allow normal Waypoint plotting and YEOMAN Waypoint plotting a change-over switch on the input to the RADAR should be fitted as follows:

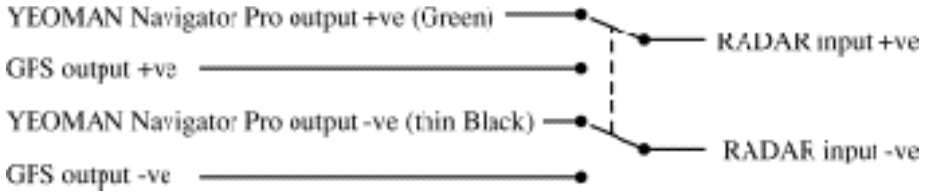

## 15. Specifications

### 15.1 YEOMAN Navigator Pro

Power supply	10-15 volts DC, 250mA
Operating temperature	0-45 °C
Display (on Mouse)	LCD, 90° viewing angle
Function controls	7 tactile keys
Illumination	LCD backlighting and chart light
Overall dimensions	725 x 535 mm / 28.5 x 21.1 inch
Active area	610 x 430 mm / 24.0 x 16.9 inch
Weight	825 g / 1.8 lbs
Plotter resolution	Better than 2mm / 0.08 inch
Chart projections	Mercator and port plans
Chart library	500 User charts
Waypoint library	500 Waypoints
Memory retention	Minimum 36 months
External NMEA 0183 Interface	4800 Baud, 8 data bits, 1 stop bit, no parity Output: TTL levels (0V and 5V) Input: opto-isolated, 0V and 2V (min) to 20V (max) Maximum reverse voltage 20V Maximum current requirement: 50mA (at +20V)
Input (NMEA 0183)	Sentences: GGA, RMC, GLL, VTG, VHW Prioritised in order shown
Output (NMEA 0183)	Sentences: WPL GLL on  key in YEOMAN mode VTG, BWC

## 15.2 YEOMAN GPS Navigator Pro

The specifications for the YEOMAN GPS Navigator Pro are the same as for the YEOMAN Navigator Pro except for the following:

Power consumption	300 mA, normal operating mode
GPS antenna dimensions	57 x 97 x 37mm / 2.2 x 3.8 x 1.5 inch
GPS antenna weight	0.125 kg / 0.275 lbs
Chart datums	101
GPS Receiver	Tracks and uses up to 12 satellites
Output (NMEA 0183)	Sentences: As YEOMAN Navigator Pro XL, plus GGA, RMC, XTE
Time to fix:	
Reacquisition	Less than 2 seconds
Warm	15 seconds, all data known
Cold	45 seconds, position, time and almanac known
Sky search	5 minutes, no data known
Update rate	1 second
Accuracy	15 metres RMS, reduced to 100 metres 2 DRMS with Selective Availability (SA)

## 16. Mounting options

### 16.1 Mounting YEOMAN to chart mat top

The standard method of mounting the YEOMAN is by securing it to the top of a chart table or similar. This can be done using double sided adhesive pads or tape.

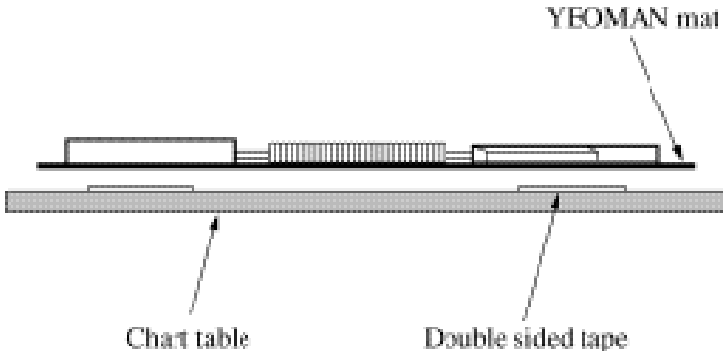

### 16.2 Under table mounting

It is possible to mount the YEOMAN under the chart table in order to leave the chart table as clear as possible. Plywood may be used to support the Plotting Board or double sided adhesive tape or similar will suffice. The YEOMAN mat becomes hidden and the system will operate through a wooden chart table top up to 10mm thick.

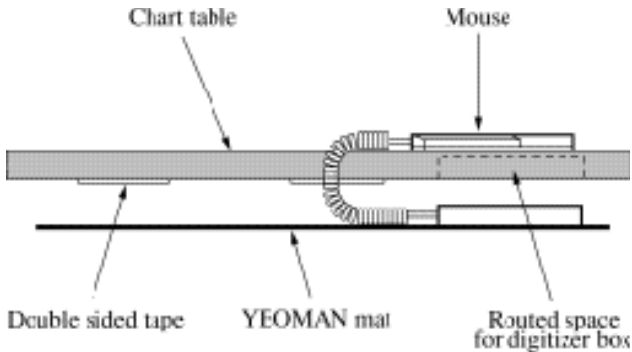

## 16.3 Under table mounting reversed

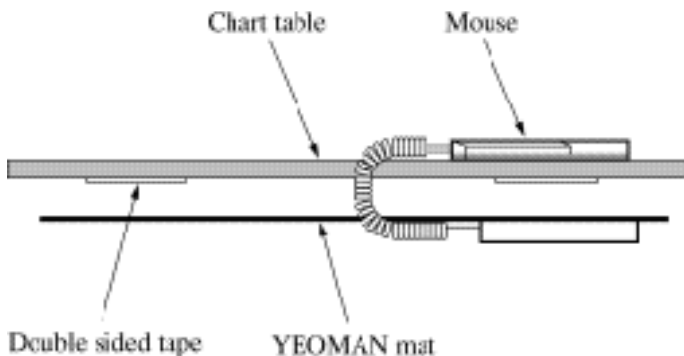

It is also possible to mount the YEOMAN upside down under the chart table.



To set YEOMAN for under table use when reversed, switch power on with  held down. Hold down until display shows



S051

Select Yes with  and accept with . Switch the power off and on again to resume normal operation.

## 16.4 Mouse cable

When fitting on the rear of the chart table do not, under any circumstances, cut and rejoin the mouse curly cable. YEOMAN can supply for purchase, a specially designed bulkhead connector for the mouse.

## Appendix A: YEOMAN to Garmin GPS 12XL,II,III,45

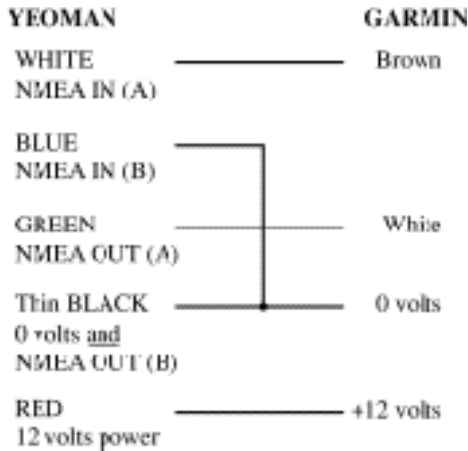

YEOMAN screen (braiding or thick black wire) is optional.  
Connect to ship's ground or 0 volts.

### YEOMAN Navigator Pro setup

NMEA-0183 (factory default)

### Garmin setup

Use I/O set up.

Select: NMEA/NMEA.  
NMEA 0183 1.5  
4800 baud

## Appendix B: YEOMAN to GARMIN

120,120XL,125,126,128,130,135,210,215,220,225,230 & 235

### CONNECTION DETAILS WITH YEOMAN PLOTTER

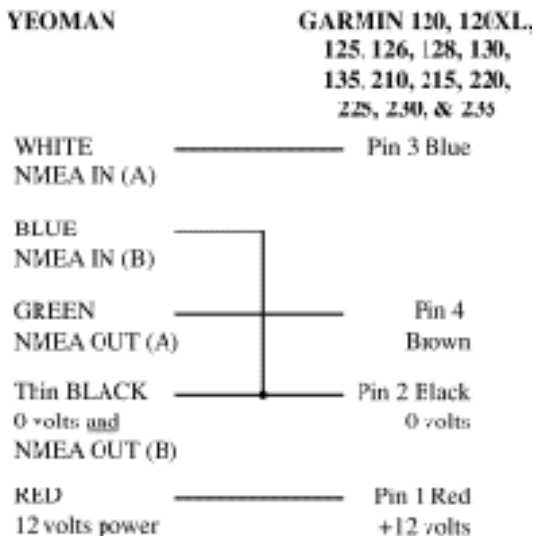

YEOMAN thick black (screen) is optional. Connect to ship's ground or 0 volts

#### YEOMAN setup:

NMEA-0183 (factory default)

#### GARMIN setup

See page 45-46 in GPS 120 manual; page 54 in 120xl manual. Always make sure that you use I/O setup.

Select       NMEA/NMEA  
                  NMEA 0183 1.5  
                  4800 baud

Note that Garmin software version 2-00 or later will accept waypoints from the YEOMAN. Note also that some early GPS units were shipped with interface cables with different coloured wires from the above; if so contact for an updated interface cable.

## Appendix C: YEOMAN to Philips AP8 & AP9 GPS

YEOMAN	—————	AP8 & AP9
WHITE NMEA IN (A)	—————	3 RED in cable marked 'NMEA Out'
BLUE NMEA IN (B)	—————	1 Smooth wire in 'MCB' cable
GREEN NMEA OUT (A)	—————	2 RED in cable marked 'NMEA In'
	—————	7 BLUE in cable marked 'NMEA In'
Thin BLACK 0 volts and NMEA OUT (B)	—————	5 BLACK in power cable
RED 12 volts power	—————	9 RED in power cable

YEOMAN screen (braiding or thick black wire) is optional.  
Connect to ship's ground or 0 volts.

### YEOMAN Navigator Pro setup

NMEA-0183 (factory default)

### AP8 & AP9 setup

None required

The display of a Waypoint will not update after a Waypoint has been sent until you scroll away from it and back.

## Appendix D: YEOMAN to PC

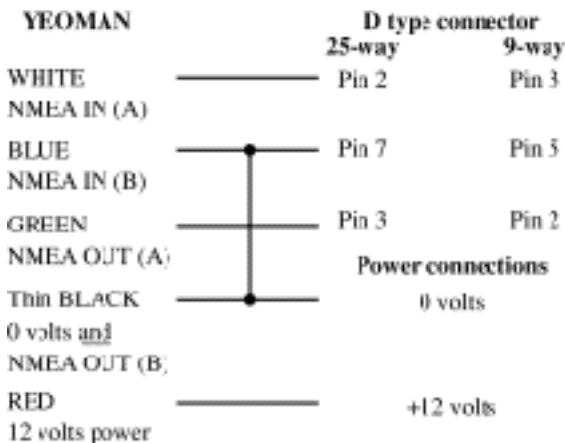

YEOMAN screen (braiding or thick black wire) is optional. Connect to ship's ground or 0 volts.

### Caution

Applicable when PC is powered from DC source only. This wiring connects the logic ground of the PC to ship's 0 volts. On some PC's this may cause damage to the PC. Seek advice from PC manufacturer or arrange to power PC from supply isolated from ship's 0 volts.





