

YEOMAN.

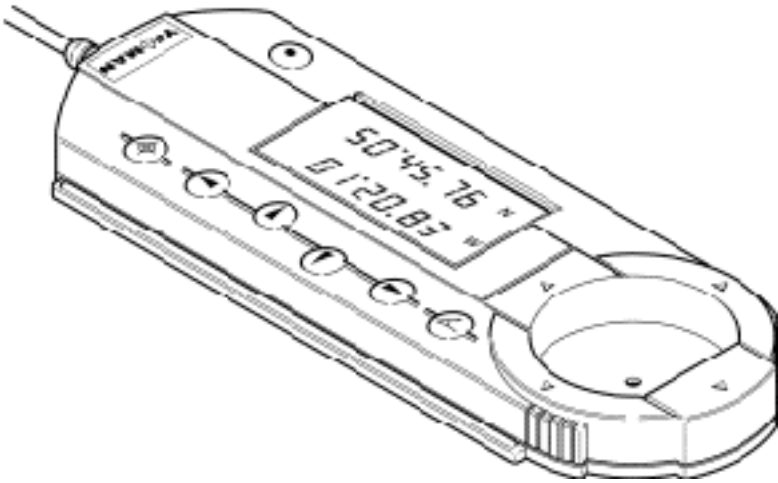

YEOMAN Sport User Handbook

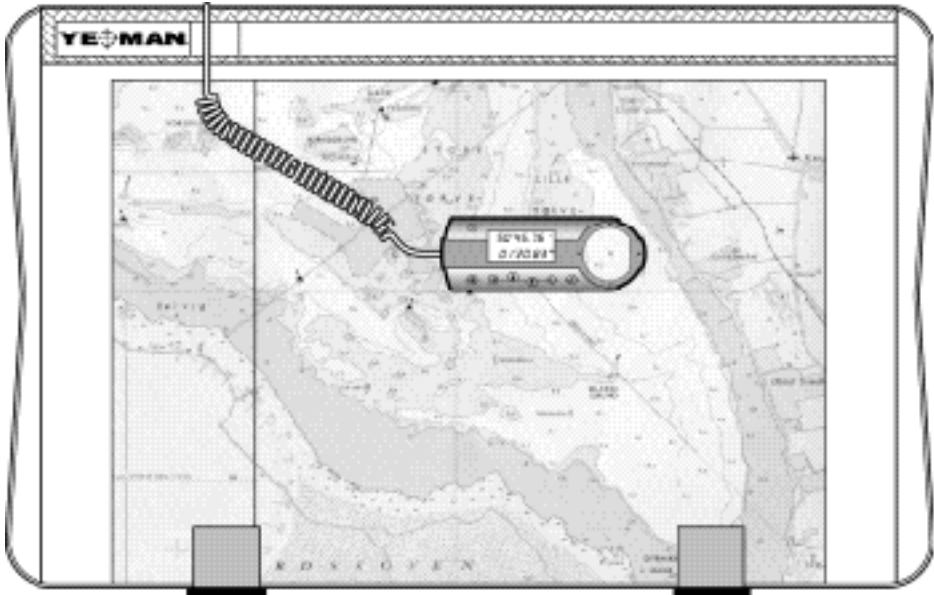

YEOMAN is a trademark of YEOMAN Group plc registered in the UK and USA and applied for in the European Union.

To the best of our knowledge and belief, the information contained within this handbook is correct and complete at the time of printing. However, YEOMAN reserve the right to change or improve the product according to technical developments. Any such developments will be described in addendum leaflets supplied with the product. YEOMAN accept no liability for information contained within this handbook which has been superseded by such addenda.

© YEOMAN 1998. All rights reserved.

Introduction

Brief description

The YEOMAN Sport is a portable chart plotter that provides all the features of electronic plotting while using all the benefits of conventional paper charts. Its full capabilities are realised when interfaced to a GPS, LORAN or DECCA receiver, which enables the YEOMAN Sport to show vessel's position directly on the chart.

About this manual

This Manual covers the operation of the following YEOMAN products:

- YEOMAN Sport
The portable YEOMAN product for coastal navigation. It contains pre-loaded chart libraries for UK small format charts and for other countries.
- YEOMAN Sport XL
A higher specification version of the YEOMAN Sport that allows connection to suitable RADARs. The YEOMAN Mouse is then connected to the RADAR screen.
- YEOMAN GPS Sport XL
A self-contained 'plug & go' full function 12 channel GPS that provides all YEOMAN Sport XL functions including RADAR plotting.

Package contents

- Portable chart table with chart cover
- YEOMAN Mouse, with cable
- 2m long Power/Data cable (6 pin plug to bare ends)
- Practice chart (part of packaging graphic)
- This user handbook.

The YEOMAN Sport XL additionally contains:

- Carrying strap
- Set of pens
- Separate Power (only) cable (2 pin plug to bare ends)

The YEOMAN GPS Sport XL additionally contains:

- External GPS antenna with 9m cable and 5 pin plug
- 0.3m long Interconnect cable (6 pin plug to 5 pin socket) instead of Power/Data cable.

When you have confirmed that all these items are present within the package, please fill in, tear off and return the warranty registration card at the back of this manual. This will allow you to receive prompt and expert support if the need arises.

Warning

The YEOMAN Sport chart plotter is a secondary navigational instrument which relies on data entered by the Navigator as well as primary satellite or radio navigation sources. Prudent navigational procedures indicate that primary navigational techniques such as visual bearings, soundings and the computation of an estimated position must, in all cases, be used in conjunction with secondary electronic navigational equipment such as the YEOMAN Sport.

Disclaimer

YEOMAN and its Suppliers, Distributors and Agents shall not be liable for accidents occurring through misuse or malfunction of YEOMAN Sport units.

Safe compass distance

Ensure that all elements of the unit are mounted at least one metre away from compass sensors.

Datum

When using GPS, especially on larger scale charts, it is important to set the GPS Datum to the same as that of the chart being used. Failure to do so will result in incorrect position plotting.

Projection

The YEOMAN Sport will work with all Mercator projection charts of all scales. It will also work with larger scale maps and charts of other projections, e.g. Transverse Mercator and Gnomonic. Small plotting errors may be apparent on non-Mercator charts with a scale smaller than 1:50 000.

Patents

Patents granted in the following countries: Australia, Belgium, Denmark, France, Germany, Holland, Hong Kong, Italy, Japan, Luxembourg, Norway, Singapore, South Korea, Sweden, Switzerland, UK and USA.

The YEOMAN Sport is manufactured under licence from QUDOS BV.

Warranty terms

YEOMAN warrants the unit to be free from defect in parts, material and workmanship for a period of 12 months from the date of purchase, either direct or from an authorised dealer. The benefit of this Warranty applies only to the original purchaser. Claims may not be made more than 18 months after despatch of the unit from our factory. Evidence of purchase such as prompt return of the Warranty Card will be required. This Warranty does not affect the statutory rights of the purchaser.

YEOMAN will repair or replace, at its option, any unit in respect of which a valid Warranty Claim shall be made on a return to YEOMAN basis. The cost of repair or replacement will be charged to the customer if the unit has been misused, damaged, tampered with by unqualified personnel or suffered severe environmental exposure including immersion in water.

European Standard EN 60945 (CE Mark)



The YEOMAN Sport meets the standards set out in European Standard EN 60945: 1993 for marine navigational equipment, class B.

Under exceptional circumstances (e.g. a VHF transmission with aerial laid close to the YEOMAN Sport) it may be possible to cause temporary malfunction of the YEOMAN. The YEOMAN Sport will recover normal operation when the source of the transmission is removed.

Manufacturer

The YEOMAN Sport chart plotter is manufactured by YEOMAN who can be contacted as below:-

Web site <http://www.yeomangroup.plc.uk>

Europe

YEOMAN

The Shipyard, Bath Road, Lymington, Hants SO41 9YL, UK

Tel. +44 (0)1590 679777 Fax +44 (0)1590 671717

Email navigation@yeomangroup.plc.uk

USA

YEOMAN

222 Severn Avenue, Annapolis, MD 21403-2569, USA

Tel. 410 263 7335 Fax 410 263 8318

Email yeomangrp@aol.com

Divisions of YEOMAN Group plc

Table of Contents

1. OVERVIEW	9
1.1 The YEOMAN Mouse	9
1.2 Main YEOMAN modes	10
1.3 YEOMAN main mode map	11
2. INSTALLATION	12
2.1 General installation notes	12
2.2 Installation	13
2.3 Power up and initial test	14
3. DEMONSTRATION MODE	15
4. BASIC OPERATIONS	16
4.1 Keypad	16
4.2 Magnetic/True headings	18
4.3 Default hemispheres	18
5. CHART LIBRARY AND REFERENCING	19
5.1 User chart library	20
5.2 Pre-loaded chart library	22
5.3 Referencing the chart	23
6. YEOMAN (PLOT) MODE	25
7. NAVIGATION MODE	26
7.1 Integral GPS (YEOMAN GPS Sport XL only)	27
8. WAYPOINT MODE	29
8.1 Manual Waypoint entry	30
8.2 Sending Waypoints to a GPS	30
8.3 Autopilot output (YEOMAN GPS Sport XL only)	31
9. DEAD RECKONING	34

10. SPORT XL AND GPS SPORT XL RADAR FUNCTIONS	36
10.1 Overview	36
10.2 RADAR plotting	37
10.3 RADAR troubleshooting	39
11. ADVANCED FEATURES	40
11.1 Setup mode	40
11.2 Memory Reset	44
11.3 Freeze Mode	44
11.4 Lock mode	45
11.5 Two position referencing	45
12. TROUBLESHOOTING	46
13. DATUM LIST	47
14. INTERFACING DETAILS	50
14.1 YEOMAN Sport	50
14.2 YEOMAN GPS Sport XL	52
14.3 RADAR data change-over switch (GPS XL and XL)	52
15. SPECIFICATIONS	53
15.1 YEOMAN Sport and YEOMAN Sport XL	53
15.2 YEOMAN GPS Sport XL	54

APPENDIX A: YEOMAN TO GARMIN GPS 12XL, 11, 111, 45

APPENDIX B: YEOMAN TO GARMIN

**120, 120XL, 125, 126, 128, 130, 135, 210, 215, 220, 225,
230 & 235**

APPENDIX C: YEOMAN TO PHILIPS AP8 & AP9 GPS

APPENDIX D: YEOMAN TO PC

1. Overview



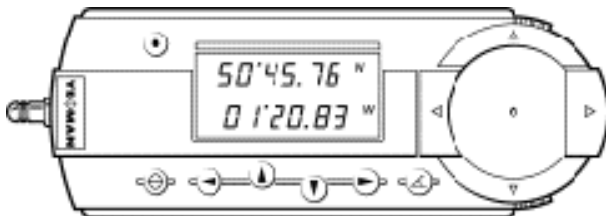

1.1 The YEOMAN Mouse



Plot Spot - the hole located in the centre of the lens which lets you plot a GPS or Waypoint position using a pencil.

Indicator arrows - the illuminated arrows representing North, South, East and West. These lights when illuminated will guide the Plot Spot to a GPS or Waypoint position.

GPS - Global Positioning System. Throughout this manual “GPS” is used to refer to all electronic positioning systems, as GPS is the most widely used. Other systems such as DECCA and LORAN may be used instead.

-  The Enter key. To accept data entries.
-  The Scroll key. Moves between operating modes.
-  The Range and Bearing key. This key is used to display the range and bearing to or from the Mouse while in YEOMAN, Navigation or Waypoint modes.
-  The Shift keys (left/right keys). Use these keys to highlight individual digits to allow data entry. Also use these keys to scroll to Dead Reckoning mode.
-  The Numeric keys (up/down keys). Operation of these keys will increase/decrease any numeric entries.

1.2 Main YEOMAN modes

1.2.1 Chart select

Used to reference a chart on the YEOMAN Sport. A chart must be referenced before any action is possible.

1.2.2 YEOMAN (plot)

The latitude and longitude of the current Mouse position is displayed. Ranges and bearings between points can also be displayed.

1.2.3 Navigation

When interfaced to a GPS, its position will be displayed and the indicator lights will point to that position on the chart. Ranges and bearings to or from the GPS position can be displayed. Course and speed over ground can be displayed, as can Time To Go to any chart position.

1.2.4 Waypoint

A Waypoint can be entered and stored either directly off the chart or manually through the keypad. It can also be transferred directly to most GPS units. Up to 100 Waypoints can be stored and recalled by their allocated numbers.

1.2.5 Dead reckoning

This mode allows for the calculation and plotting of Dead Reckoning position.

1.2.6 Set-up

To set-up interfacing and other selectable parameters.

1.3 YEOMAN main mode map

This mode map shows the relationship between the main YEOMAN modes.

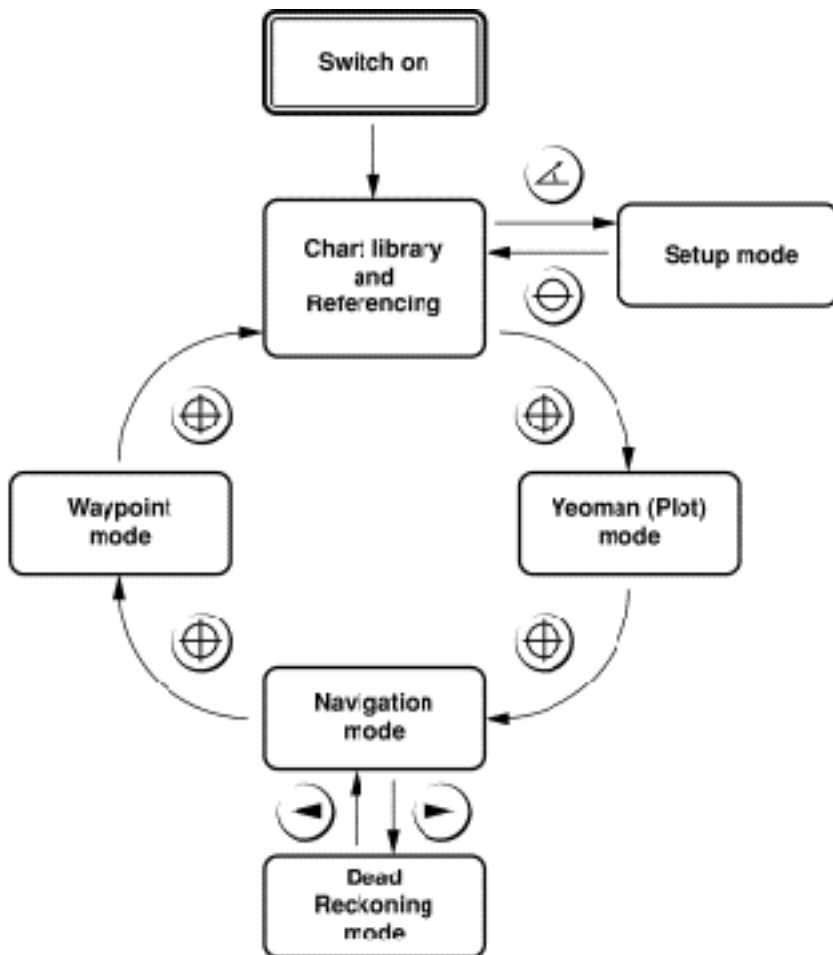

2. Installation

2.1 General installation notes

The YEOMAN Sport requires a power supply of 12V DC. Application of overvoltage will blow an internal fuse which will require the unit to be returned to a service dealer. It is also advisable to fit a surge protective fuse into the 12V power connection.

The chart table must not be cut or drilled.

The YEOMAN Mouse curly cable should not be cut or interfered with in any way. No metal should be within 50mm of the chart table in any direction. The active area of the chart is approximately 50mm in from the edges. Indicator lights will flash when the Mouse is outside this area.

The YEOMAN is reverse polarity protected and is designed for negative earth systems. Connection to positive earth systems should only be made by qualified personnel.

Although the YEOMAN is marinised, it should be kept clean and dry.

Four D ring anchor points are provided to secure the chart table.

Do not write on the chart cover with indelible pen or ball-point.

2.2 Installation

2.2.1 YEOMAN Sport and YEOMAN Sport XL

Make the following connections:

WHITE	(A) input to YEOMAN from GPS
BLUE	(B) input to YEOMAN from GPS
GREEN	(A) output from YEOMAN to GPS
THIN BLACK	0 volts and (B) output from YEOMAN to GPS
RED	12 volts DC power
THICK BLACK (SCREEN)	Connect to ground or 0 volts, optional

For further information refer to Section 14.

2.2.2. YEOMAN GPS Sport XL

Make the following connections:

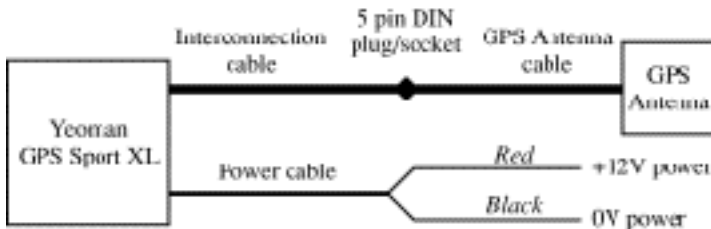

Mount the GPS antenna with its base horizontal and so that it has a clear view of the sky from horizon to horizon. The standard antenna is supplied in flush mount configuration - a pole mount kit is supplied which fits onto a standard 1" antenna mount. Connect the GPS antenna cable to the YEOMAN using the short Interconnect cable.

For further information refer to Section 14.

2.3 Power up and initial test

Apply power to the YEOMAN. The Mouse will emit an audible 'beep', the indicator lights will illuminate and text will appear on the display.

Lift the Mouse away from the chart table and the indicator lights will flash, put the Mouse on the centre of the chart table and all lights will stay on. This shows that the YEOMAN is functioning correctly and is ready for use.

3. Demonstration mode

All you need to get YEOMAN going is 12 volts DC.

A self-demonstrator is supplied to help gain familiarity with YEOMAN. This is set automatically when shipped and uses the practice chart contained in the packaging graphic in the chart case.

After power on, place the Mouse Plot Spot over the point marked "REF 1", and press . Repeat for points 2 and 3.

The YEOMAN will now enter YEOMAN mode and most functions of the YEOMAN may be used. In Navigation mode a simulated position and velocity allows familiarity to be gained.

The YEOMAN will exit Demonstration mode the first time that you reference a real chart. Section 11.1 describes how to re-enter demonstration mode.

When Demonstration mode is set then the supplied practice chart must be used and the four red indicator lights will flash together every 10 seconds in all YEOMAN modes.

4. Basic Operations

4.1 Keypad

The YEOMAN uses the four arrow keys (▲▼▶◀) to enter numeric data such as Chart and Waypoint numbers, latitude and longitude.

4.1.1 Entering Chart and Waypoint numbers

When selecting any of these numbers, the right hand digit will flash, indicating that you can enter or change a number.

For example, to enter the chart number 34:



S004

Press (▲). The flashing digit will increase by 1. If you press and hold (▲), the number will increment until it reaches 9, and then start counting again from 0. The (▼) key reduces the flashing digit by 1.

Press  until the display reads:



S005

Press . The left hand digit will start to flash.



S006

Press  to change the number to 3.

When the correct number is displayed, press  to accept.

4.1.2 Entering latitude and longitude

Latitude and longitude are entered and displayed in degrees, minutes and decimal minutes (2 places).

When a latitude and longitude need to be entered, the first digit of latitude will flash.

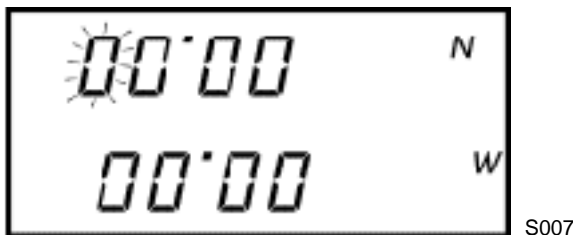

Enter the latitude using the \uparrow \downarrow and \leftarrow \rightarrow keys. Use \rightarrow to set N/S flashing then use \uparrow to toggle as required.

Press \rightarrow until the first digit of longitude is flashing.

Enter the longitude using the \uparrow \downarrow and \leftarrow \rightarrow keys.

To enter a longitude with degrees greater than 99° press \downarrow when the leftmost zero is flashing.

Use \rightarrow to set E/W flashing then use \uparrow to toggle as required.

Press \rightarrow to confirm and enter the numbers.

4.2 Magnetic/True headings

All bearings are normally displayed as magnetic. The Setup section 11.1 describes how to change this to true.

4.3 Default hemispheres

The default hemisphere for entry of all latitude and longitude is determined by that set in reference position 1 of User Chart 00.

5. Chart library and referencing

Before using YEOMAN, a chart must be entered into the CHART LIBRARY and referenced. This requires the entry of the latitude and longitude of three positions on the grid intersections as below. The positions should be as far apart as practicable and marked clearly.

THE LATITUDE OF POSITION 2 MUST BE THE SAME AS THAT OF POSITION 1. THE LONGITUDE OF POSITION 3 MUST BE THE SAME AS THAT OF POSITION 2.

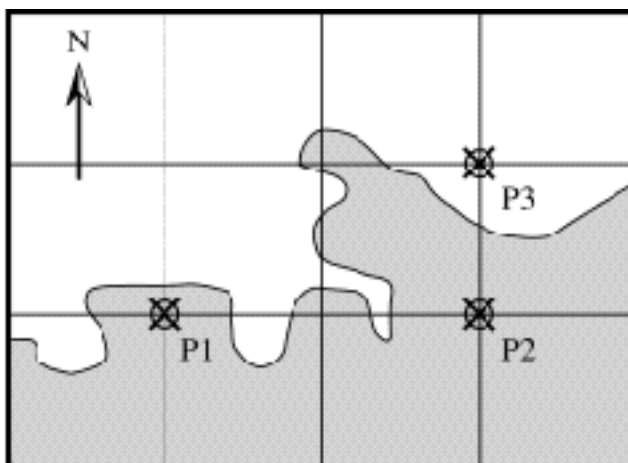

IF THE CHART MOVES ON THE CHART TABLE AFTER REFERENCING IT MUST BE RE-REFERENCED.

Position 1 and Position 2 must be further than 50mm apart.

It is possible to reference a chart with only two reference positions and this is described in Section 11.5.

For units shipped in the USA with the BBA Chartkit library then Positions 1, 2 and 3 are replaced by Positions A, B and C.

Should a chart need to be overwritten at any stage, in chart select mode hold down  for six beeps. The position entry facility is displayed and the latitude and longitude of the positions can be altered.

YEOMAN can be used with any general chart providing that first three reference points are entered as in 5.1 below. Once entered these points are stored and build a library of User Charts.

Some chart publishers are adding special pre-plotted YEOMAN reference points to charts to make these even easier to use with YEOMAN, again entering these as in 5.1 below. Similarly once entered these points are stored.

For some of these pre-plotted charts YEOMAN pre-load a library in the YEOMAN Sport. Details of which such pre-loaded charts are in your unit are contained in a supplementary card with this handbook.

If the chart you are using has pre-printed reference points and is in the list on the supplementary card then go to Section 5.2.



Otherwise follow the instructions below.

5.1 User chart library

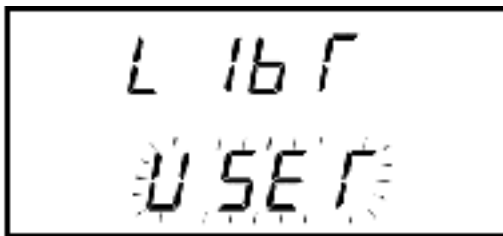



The display should flash:



SO42

If not use   to get the display then accept with .

Select three reference points on the chart, mark them clearly, and number them P1, P2 and P3.

Allocate a user chart library number (00-99) and write it on the edge of the chart for future reference. At the 'Select Chart' display, use the     keys to select the chart number.



If you select a chart number which has already been used the display reads:



Press  to accept the chart number.

The display then shows P1 (Position 1). The first digit of latitude will flash.





S007

Enter the latitude and longitude for P1, ensuring that N/S and E/W are entered correctly (see Section 4.1.2).

Press  to accept Position 1 (P1).

Enter the latitude and longitude for Position 2 (P2) and Position 3 (P3) in the same way.

If a mistake is made during the entry of any of the positions press  and then hold  down for six beeps. The display will revert back to the position entry facility where the latitude and longitude of the positions can be edited.

Now go direct to Section 5.3.

5.2 Pre-loaded chart library

Use  to get the display flashing the YEOMAN design-nation of the pre-loaded library that you wish to use. For instance for UK Admiralty Small Craft Edition scroll until

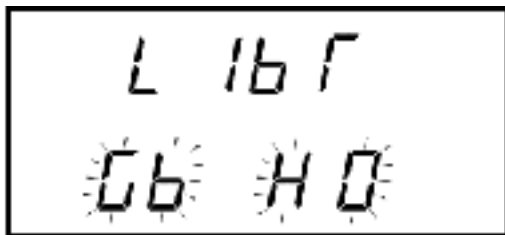

SO43

is displayed flashing.

For Chartkit library scroll until

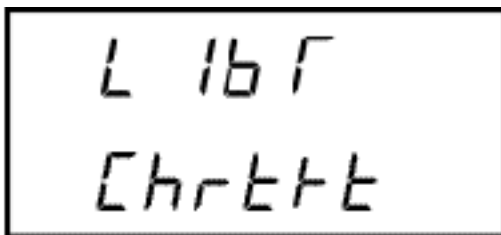

S044

is displayed flashing.

Select the pre-loaded library with \odot .

Select the chart set required. For example with UK Admiralty charts select Folio 5600, 5604 etc. using \blacktriangle . For Chartkits, select the Region using \blacktriangle .

Select chart number in series required (see Section 4.1.1).

5.3 Referencing the chart

The display will now read:

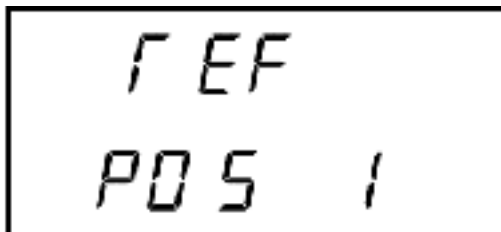

S009

Align the Plot Spot over chart reference Position 1. Press \odot . Repeat action for Positions 2 and 3.

During referencing the latitude and longitude of the reference points can be displayed by pressing \blacktriangle .

If the chart has been referenced correctly the YEOMAN will advance to YEOMAN (PLOT) mode after Position 3 has been accepted. A quick check of the referencing should be made on a suitable point (such as another grid position) and the display should be compared with a chart position.

If the referencing has been done incorrectly the indicator arrows flash and the display shows:



S013

In this case there has been one of:

- Incorrect positioning of the Mouse or chart moved during referencing. Press ⊕ to return to chart referencing and then reference again carefully.

Or

- Incorrect or inconsistent latitude/longitude of one or more of the reference positions. Press ⊕ to return to chart referencing and re-reference, this time displaying the latitude and longitude of the reference points by using ▲, as described earlier. Specifically check N/S and E/W entries are correct and that P1 and P2 are more than 50mm apart.

Or

- One of the reference points is outside the active area. The indicator lights will flash when over the position. Select a new reference point or re-position chart.

Depending on the result either correct the reference position latitude and longitude as described earlier, or mark corrected reference positions on the chart.

6. YEOMAN (plot) mode

This mode is used for normal chart work and for obtaining range and bearing between points.

The YEOMAN goes to this mode when referencing is completed; or press \oplus until YE appears on the display.

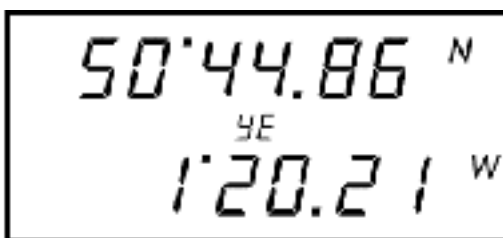

S014

The display will now indicate the latitude and longitude of the Plot Spot position as the Mouse is moved.

To memorise a chart position place the Plot Spot over it and press \odot , the indicator arrows extinguish.

This action also outputs a 'GLL' position on the NMEA 0183 output line.

Press \triangleleft to get Range and Bearing to anywhere on the chart the Mouse is placed from the memorised position.

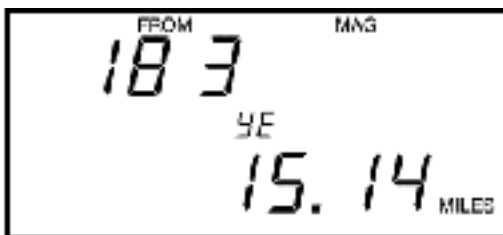

S015

Toggle to the reciprocal bearing by pressing \blacktriangledown . Holding down the \blacktriangleup displays the reciprocal bearing Press \triangleleft to return to latitude/longitude display.

The illuminated arrows will show the direction to the memorised point.

7. Navigation mode

This mode allows the current position from a GPS to be plotted directly on to the chart. Scroll with \oplus to Navigation (NA) mode.

If the indicator arrows flash the YEOMAN is not receiving valid data from the GPS. Refer to Section 14.

The latitude and longitude of the GPS position is displayed, and is updated every few seconds.



S017

One or two of the indicator arrows will illuminate and point to the position on the chart. Move the Mouse in the direction the arrows indicate until they are all extinguished. The Plot Spot is now over the GPS position, and this can be plotted using a pencil through the Plot Spot hole.

Press \triangleleft to get Range and Bearing to anywhere on the chart the Mouse is placed from the current GPS position in a similar way to that in YEOMAN mode.

Press \blacktriangledown to display Course over Ground (CO) and Speed over Ground (SP), in knots, from the GPS.



S018

Press \blacktriangle to display Time to Go (tt GO). This will show the time to go in hours and minutes from ship's position to the Plot Spot at the current speed over ground. The calculation does not take into account current course.

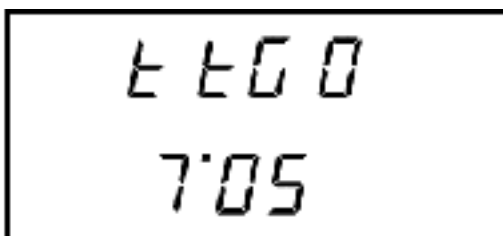

S019

7.1 Integral GPS (YEOMAN GPS Sport XL only)

All GPS information is displayed in the (NA) Navigation page. If no fresh GPS data is available, then the last good position will be shown and all indicator lights will flash.

Pressing the \blacktriangledown key will then display the first GPS display page:

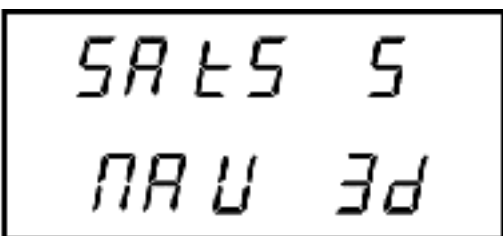

S020

The upper line indicates the number of satellites currently in view. This will normally be zero or a small number when the unit is first turned on and then increase as satellites are found.

If the upper line shows '-' then this indicates that no data is being received from the GPS antenna. Check all connections and if necessary contact a service dealer. If a zero or any other number is shown then this indicates that data is being received.

The lower line shows the mode of navigation. 0d indicates no fix available while two and three dimensional fixing are indicated by 2d and 3d respectively.

The second GPS page is accessed with a further press of the  key:

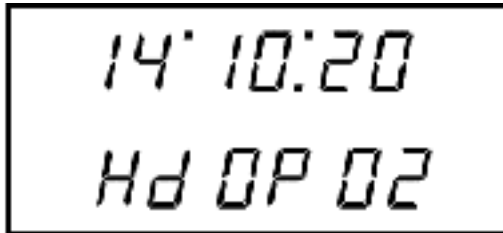

S021

Now the first line shows GPS time in Universal Time (effectively GMT).

The lower line shows the Horizontal Dilution of Position (1-99) which is a measure of quality of fix (lower number means higher geometric quality).

Pressing  twice steps back through the first GPS page to the Navigation display.

8. Waypoint mode

Waypoints can be entered directly from the chart, or manually using the Mouse keys. The YEOMAN will also send the Waypoint information to a GPS receiver.

Press \oplus to scroll to WAYPOINT mode.

Select the Waypoint position on the chart and allocate a number (00-99) from the Waypoint Library. Mark the Waypoint on the chart and write the number beside it in pencil.



S022

Set in Waypoint number using \downarrow \uparrow \rightarrow \leftarrow . Place the Plot Spot on the Waypoint position on the chart and press \bullet to enter.

The Waypoint is entered and in the Waypoint library. The indicator arrows extinguish and the latitude and longitude of the Waypoint position are displayed.

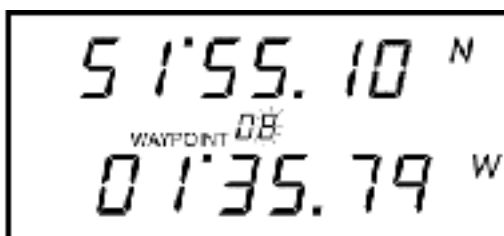



S023

When the Mouse is moved, one or two indicator arrows will illuminate and point to the Waypoint position on the chart.

Waypoints already stored are overwritten if a new position is entered using the same number. If an existing Waypoint is accessed, its position will appear on the display and the indicator arrows will show its position. Consequently a Waypoint stored in the Waypoint library can be transferred from chart to chart.

Press  to get Range and Bearing to anywhere on the chart the Mouse is placed from the current Waypoint position in a similar way to that in YEOMAN mode.

8.1 Manual Waypoint entry

To manually enter a Waypoint set the Waypoint number then press  and hold down for six beeps. Set in the latitude and longitude of the Waypoint, as in Section 4.1.2. Press  to accept Waypoint.

8.2 Sending Waypoints to a GPS

8.2.1 General

When a Waypoint is entered into the YEOMAN its number and position is transmitted to the GPS via the NMEA 0183 output. A GPS with a suitable NMEA 0183 input capability will be able to accept the Waypoints directly from the YEOMAN.

8.2.2 Special considerations

There are a few important points to consider when sending Waypoints to a GPS and some checks are worthwhile:

- Is the GPS capable of receiving Waypoints from another piece of equipment? Does it have an input port and, if so, does it accept the correct data? Please consult your GPS handbook, your dealer or YEOMAN.
- Are the connections correct? Refer to Section 14.
- Some GPS allow their Waypoints to be overwritten - in the same way as YEOMAN does and some do not.
- Some GPS do not change the displayed Waypoint on entry from YEOMAN. Scroll the GPS display away from Waypoint entered and then scroll back to view the new Waypoint position.
- Waypoint 00 is never transmitted.
- The YEOMAN can be set to append 100 to 900 to Waypoint numbers (i.e. Waypoint 12 can be sent as 112) to write into specific Waypoint banks on some GPS units. See Section 11.1.1 for details.

8.3 Autopilot output (YEOMAN GPS Sport XL only)

Provided that the YEOMAN GPS Sport XL is receiving position then output is sent out to drive an autopilot.

To do this set or select an end Waypoint with number anything except 00. Once this destination Waypoint is selected then use the ⊕ key to move on from the Waypoint page. At this point the run-line to be followed is set between the current GPS position and the selected destination Waypoint. Autopilot information will then start to be transmitted while the GPS is still obtaining a valid fix.

Once started, autopilot data will be sent and stopped only by:

1. GPS loss of signal. Autopilot data will cease, but resume when GPS signal re-acquired, subject to other conditions below.
2. Reaching the destination Waypoint in the sense shown in the diagram below:

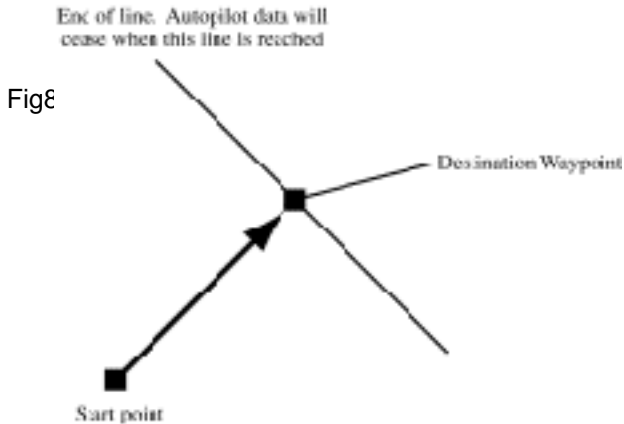

3. Selecting Waypoint 00.
4. Turning unit off then on again, destination Waypoint will be preserved, but must be reactivated by selecting Waypoint page and moving on past it again, ⊕ key.

If a 'null' Waypoint is selected then autopilot information will continue to be transmitted to the last valid Waypoint selected.

When valid autopilot data is being transmitted then the Navigation (NA) and YEOMAN (YE) display pages will have the WAYPOINT flag in the centre of the LCD display showing.

On the Waypoint page, it is possible to scroll through and enter Waypoints other than the current destination Waypoint without disturbing the autopilot output. The TO flag on the upper edge of the LCD display will show on the destination Waypoint only.

If the position of the current destination Waypoint is changed, then the output to the autopilot changes immediately to the new position from current GPS position. This gives the powerful 'point and go' method of driving an autopilot. If a Waypoint other than the current destination is selected when the Waypoint page is left then this new point will become the destination, starting from the current GPS position.

No facility for holding routes is provided. When a Waypoint is reached, select the next point by setting the Waypoint either from the library or by putting the Mouse over next destination point and updating current Waypoint (pressing ).

To disable output select Waypoint 00.

There is no display of cross-track offset as this can very simply be picked off the chart using the normal YEOMAN plotting facilities.

9. Dead reckoning

This mode allows for the calculation and plotting of position by Dead Reckoning (DR).

If the Tidal Direction and Rate are input as well as Course and Speed then these will be included in the calculation in order to enable an Estimated Position (EP) to be plotted.

Scroll with \oplus to NA mode and press \ominus to DR Mode. Place the Plot Spot on ship's current position on the chart and press \odot . The latitude and longitude of the position are displayed.

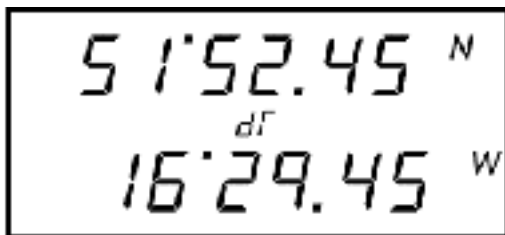

S025

YEOMAN will update this and the DR position can be plotted using the indicator arrows, as in the NA mode. Refer to Section 7.

To set DR Course, Speed and Tidal data press \oplus . To exit DR mode press \ominus . The display shows:



S026

Using \rightarrow \leftarrow \uparrow \downarrow set course. Press \odot to accept.

If there is an NMEA 0183 sentence "VHW" from the compass and log then course and speed will automatically up-date.

Display shows:



S027

Using \uparrow \downarrow \leftarrow \rightarrow set speed. Press \odot to accept.
The display shows:



S028

Using \uparrow \downarrow \leftarrow \rightarrow set water current direction and velocity.
Press \odot to accept.

Press \oplus to return to DR mode and then press \rightarrow to exit DR mode and return to NA mode.

At any time DR/EP position can be updated by placing the Plot Spot over an updated fixed position and pressing \odot while in DR mode.

10. Sport XL and GPS Sport XL RADAR functions

10.1 Overview

A number of small boat RADARs have a feature which displays as a 'lollipop' the next Waypoint in a sailplan from a GPS. These RADARs can, in general, also be connected to the Sport XL versions. The general arrangement of the connections is shown below:

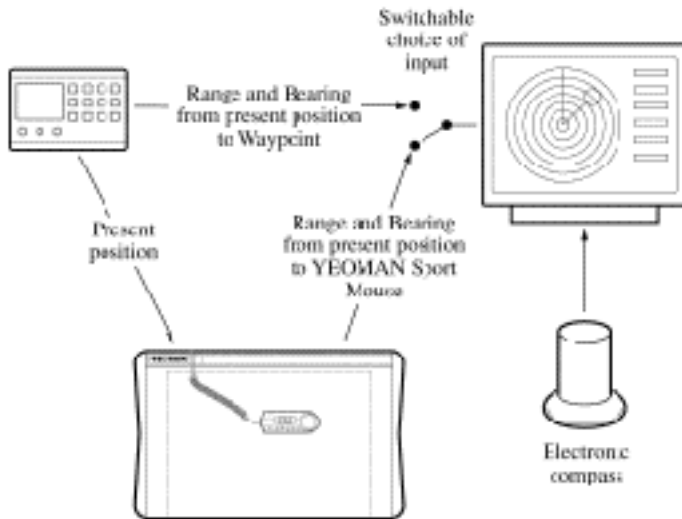



To use YEOMAN input and GPS input a changeover switch is needed as the RADAR cannot accept two inputs at the same time. Such a switch (DATABOX) is available from YEOMAN or can be made as in Section 14.3.

When the RADAR input is set to the YEOMAN, the 'lollipop' on the RADAR will track the position of the YEOMAN mouse on the chart, see Section 10.2 below. An electronic compass input is needed for the RADAR to enable this. Note that Course Over the Ground input from a GPS cannot be used in the place of a compass.

10.2 RADAR plotting

Set the YEOMAN into Navigation Mode, see Section 7, and then display range/bearing using the  key and then:

- Press the  key once to send a snap-shot of the Mouse position to the RADAR. Note that this does not automatically update. Further presses of the  key are needed to update new range and bearing to the RADAR.
- Alternatively, hold the  key down for five beeps and then release it. The YEOMAN then streams range/bearing data to the RADAR continuously from the Mouse position wherever it is moved. There may be a slight delay in the response of the RADAR 'lollipop', which varies with RADAR model and manufacturer.

As soon as range/bearing display is changed, then output to the RADAR ceases. A short period later the RADAR 'lollipop' display will then disappear and 'no data' may be flashed (dependent on RADAR used).

RADAR plotting will also function in a similar way from DR mode, Section 9.

The YEOMAN RADAR plotting system does nothing more nor less than replicate a manual plot, with the exception of being easier, quicker and less prone to manual plotting error. The sources of error are thus the same and fall into the following categories:

RADAR misalignment

Common to manual or YEOMAN plotting. See RADAR handbook or any book on RADAR for techniques on how to resolve and rectify this.

Compass misalignment or calibration error

Potentially an area where manual plotting, probably using the main steering compass, and YEOMAN plotting, based on the RADAR's electronic compass, may differ.

A careful check of the electronic compass used for the RADAR against a properly swung primary compass, taking account of the deviation card, should be made on all compass headings.

This should be checked from time to time, especially after any refit, in case the electronic compass sensor should have been disturbed or any change to its magnetic environment occurred (e.g. electrical equipment or magnetic material placed nearby).

Navigation system error

Common to either methods and the user should always remain alert to the fact that the electronic position data may be in error or may not tie up to the co-ordinates on the chart. Remedies include:

- a second independent electronic navigation system (i.e. use both GPS and DECCA or LORAN) and compare regularly
- regular checking against conventional navigation including dead reckoning, depth sounder and compass bearings on known features
- checking against RADAR, for which the YEOMAN plotting system is particularly convenient.

Plotting position error

Both manual and YEOMAN position plotting can be checked by the same methods as above. The likeliest form of error with the YEOMAN is movement of the chart since it was last referenced. If in any doubt it is sensible to re-reference, which takes but a few seconds, before plotting.

It is suggested that after initial installation, a careful check against a manual plot and known scenario (e.g. vessel held in marina berth with well identified RADAR targets such as channel markers). Regular checks against well identified targets in good conditions will assist both with functional familiarity and with confidence and reliability assessment when needed under more testing conditions.

10.3 RADAR troubleshooting

If the RADAR 'lollipop' cannot be initiated by setting the YEOMAN into RADAR plotting mode, a suggested list of symptoms and tests is given below:



- a) Ensure that RADAR is receiving compass data and is set in magnetic compass 'mode'. The RADAR will not accept range/bearing data and plot the 'lollipop' otherwise. Check the compass and interfacing to the RADAR.
- b) If the RADAR is accepting compass data then remaining areas to check are-

selection of Waypoint plotting mode on RADAR, see manufacturer's handbook

interfacing to the RADAR. Check this by linking the GPS directly to the RADAR to see if conventional GPS RADAR Waypoint plotting is working.

11. Advanced features

11.1 Setup mode



Press the  button repeatedly until you get to Chart Referencing mode. Press  to enter Setup mode. Press  to step between setup screens in the following order:

- GPS Datum (YEOMAN Sport GPS XL only)
- Year
- True/Magnetic selection
- Clear Waypoints
- GPS interface
- Waypoint prefix
- Demonstration mode selection.





11.1.1 GPS datum (YEOMAN GPS Sport XL only)



S041

This shows that the GPS Datum is number 100 (WGS 84). You can change the Datum using the  and  buttons. Refer to Section 13 for a list of datum code numbers.

11.1.2 Year

Use the     keys to enter the current year.

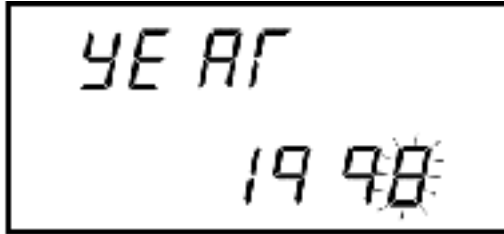

S039



This is used to calculate magnetic variation.

11.1.3 True/Magnetic selection

This option lets you change the heading definition.



S038

Yes or No can be selected using the  or  keys.

YES tells the YEOMAN to use True headings.

NO selects automatic magnetic variation.

Press  to enter your choice.

11.1.4 Clear Waypoints

This option clears ALL Waypoints stored within the YEOMAN memory.



S030

To clear the Waypoints, press \rightarrow to select Yes, and then press \odot . Otherwise, select No and press \odot .

11.1.5 GPS interface

The default GPS interface works with the majority of GPS receivers. This function selects for specific GPS units.



S033

- 00 Default, Standard NMEA 0183 - suits most receivers
- 01 Magellan 3000 XL
- 02 MLR Valsat SP
- 03 MLR Valsat 2008
- 04 Trimble NT series

Additional information on GPS types may be on a card packed with the handbook.

11.1.6 Waypoint prefix



S040

This adds a number to the Waypoint output only.

For example if the prefix is set to 200 then YEOMAN Waypoint 73 will be output to the GPS as Waypoint number 273. This allows use of multiple Waypoint banks in some GPS units.

11.1.7 Demonstration mode selection

The display will show:



S035

Select Yes or No using   then press .

When Demonstration mode is set then the supplied practice chart must be used and the four red indicator lights will flash together every 10 seconds in all YEOMAN modes.

11.2 Memory Reset



This function resets the YEOMAN to its factory defaults.

ALL INFORMATION YOU HAVE INPUT WILL BE LOST, INCLUDING CHARTS AND WAYPOINTS. THE PRE-LOADED CHART LIBRARY WILL NOT BE DELETED.



To reset the YEOMAN to its factory defaults, hold down  and switch on the power. Keep the key depressed until the display reads:



S031

Press  to select Yes, and then press . Turn the power off again. When you next turn the power on the unit will have been reset to its factory defaults.



11.3 Freeze Mode

It is possible to freeze the display while operating the Range and Bearing facility by holding down  for five beeps. This allows the Mouse to be picked up and the display read without alteration. To unfreeze the display press .

11.4 Lock mode

Whilst in Navigation mode, pressing  for two beeps locks the YEOMAN in Navigation mode, while still allowing different modes such as Satellite Info, Range and Bearing, manual Dead Reckoning, Course, Speed Over Ground and Time To Go to be accessed.

When in Lock mode the NA flag in the centre of the screen changes to NL.

Press of  for one beep or a single press of  unlocks the lock mode.

11.5 Two position referencing

The YEOMAN will operate with only two reference positions by referencing Positions 1 and 2 normally and then by referencing Position 3 on the same point as Position 2.

This method of chart referencing allows the use of small charts and insets where it might be difficult to find three suitable reference positions. It also enables the creation of a large scale Mercator plotting sheet.

REFERENCING ON TWO POSITIONS PROVIDES NO REFERENCING CHECK AND MAY RESULT IN SMALL INACCURACIES. USE THIS METHOD WITH CAUTION.

12. Troubleshooting

Problem	Possible cause	Suggested action
NO RESPONSE. NO DISPLAY OR BACKLIGHT.	A) No external power supply. B) Blown internal fuse.	A) Check battery voltage. Check polarity (red +12V, thin black 0V) Check any external fuse. B) Return to service dealer.
UNIT COMES ON AND THEN SCREEN BLANKS OR LOCKS UP.	A) Low voltage or corrupted data being transmitted to YEOMAN.	A) Check battery voltage. Temporarily disconnect input data cable.
YEOMAN DOES NOT REFERENCE CORRECTLY.	A) Incorrect reference positions. B) Reference positions outside active area. C) Reference positions too close.	A) Check Lat/Long of reference positions. B) Check positions are within the active area of the chart table. C) Check P1 and P2 are more than 50mm apart.
YEOMAN SPORT PLOTS INACCURATE POSITION.	A) Unit corrupted by metal. B) Chart has moved. C) GPS input is defective.	A) Check that there is no metal near YEOMAN Sport. B) Fix chart and re-reference. C) Check connections, interface and Datum are correct.
YEOMAN LIGHTS FLASH IN NAVIGATION MODE.	A) YEOMAN not receiving position	A) Check GPS specification. Check connections.
YEOMAN DOES NOT RETAIN REFERENCE POSITIONS.	A) Internal battery flat	A) Return to service dealer or YEOMAN.
YEOMAN LIGHTS FLASH AT TEN SECOND INTERVALS.	A) In Demo mode	A) See Section 3 and 11.1.7.

13. Datum list

INDEX	DATUM EARTH NAME	AREA OF APPLICATION
0	ADINDAN	Ethiopia, Mali, Senegal, Sudan
1	AFGOOYE	Somalia
2	AIN EL ABD 1970	Bahrain island, Saudi Arabia
3	ANNA 1 ASTRO 1965	Cocos Island
4	ARC 1950	Botswana, Lesotho, Malawi, Swaziland, Zaire, Zambia, Zimbabwe
5	ARC 1960	Kenya, Tanzania
6	ASCENSION ISLAND 1958	Ascension Island
7	ASTRO BEACON "E"	Iwo Jima Island
8	AUSTRALIAN GEODETIC 1966	Australia, Tasmania Island
9	AUSTRALIAN GEODETIC 1984	Australia, Tasmania Island
10	ASTRO DOS 71/4	St Helena Island
11	ASTRONOMIC STATION 1952	Marcus Island
12	ASTRO B4 SOROL ATOLL	Tern Island
13	BELLEVUE (IGN)	Efate and Erromango Islands
14	BERMUDA 1957	Bermuda Islands
15	BOGOTA OBSERVATORY	Colombia
16	CAMPO INCHAUSPE	Argentina
17	CANTON ASTRO 1966	Phoenix Islands
18	CAPE CANAVERAL	Florida, Bahama Islands
19	CAPE	South Africa
20	CARTHAGE	Tunisia
21	CHATHAM 1971	Chatham Island (New Zealand)
22	CHUA ASTRO	Paraguay
23	CORREGO ALEGRE	Brazil
24	DJAKARTA (BATAVIA)	Sumatra Island (Indonesia)
25	DOS 1968	Gizo Island (New Georgia Islands)
26	EASTER ISLAND 1967	Easter Island
27	EUROPEAN 1950	Austria, Belgium, Denmark, Finland, France, Germany, Gibraltar, Italy, Greece, Luxembourg, Netherlands, Norway, Portugal, Spain, Sweden, Switzerland
28	EUROPEAN 1979	Austria, Finland, Netherlands, Norway, Spain, Sweden, Switzerland
29	FINLAND HAYFORD 1910	Finland
30	GANDAJIKA BASE	Republic of Maldives
31	GEODETIC DATUM 1949	New Zealand
32	ORDNANCE SURVEY OF GREAT BRITAIN 1936	England, Isle of Man, Scotland, Shetland Islands, Wales
33	GUAM 1963	Guam Island

34	GUX 1 ASTRO	Guadalcanal Island
35	HJORSEY 1955	Iceland
36	HONG KONG 1963	Hong Kong
37	INDIAN	Bangladesh, India, Nepal
38	INDIAN	Thailand, Vietnam
39	IRELAND 1965	Ireland
40	ISTS 073 ASTRO 1969	Diego Garcia
41	JOHNSTON ISLAND 1961	Johnston Island
42	KANDAWALA	Sri Lanka
43	KERGUELEN ISLAND	Kerguelen Island
44	KERTAU 1948	West Malaysia, Singapore
45	LC 5 ASTRO	Cayman Brac Island
46	LIBERIA 1964	Liberia
47	LUZON	Mindanao Island
48	LUZON	Phillippines (excluding Mindanao Island)
49	MAHE 1971	Mahe Island
50	MARCO ASTRO	Salvage Islands
51	MASSAWA	Eritrea (Ethiopia)
52	MERCHICH	Morocco
53	MIDWAY ASTRO 1961	Midway Island
54	MINNA	Nigeria
55	NORTH AMERICAN 1927	Alaska
56	NORTH AMERICAN 1927	Bahamas (excluding San Salvador Island)
57	NORTH AMERICAN 1927	Central America (Belize, Costa Rica, El Salvador, Guatemala, Honduras, Nicaragua)
58	NORTH AMERICAN 1927	Canal Zone
59	NORTH AMERICAN 1927	Canada (including Newfoundland Island)
60	NORTH AMERICAN 1927	Caribbean (Barbados, Caicos Islands, Cuba, Dominican Republic, Grand Cayman, Jamaica, Leeward Islands, Turks Islands)
61	NORTH AMERICAN 1927	Mean Value (CONUS)
62	NORTH AMERICAN 1927	Cuba
63	NORTH AMERICAN 1927	Greenland (Hayes Peninsula)
64	NORTH AMERICAN 1927	Mexico
65	NORTH AMERICAN 1927	San Salvador Island
66	NORTH AMERICAN 1983	Alaska, Canada, Central America, CONUS, Mexico
67	NAPARIMA, BWI	Trinidad and Tobago
68	NAHRWAN	Masirah Island (Oman)
69	NAHRWAN	Saudi Arabia
70	NAHRWAN	United Arab Emirates
71	OBSERVATORIO 1966	Corvo and Flores islands (Azores)
72	OLD EGYPTIAN	Egypt

73	OLD HAWAIIAN	Mean Value
74	OMAN	Oman
75	PICO DE LAS NIEVES	Canary Islands
76	PITCAIRN ASTRO 1967	Pitcairn Island
77	PUERTO RICO	Puerto Rico, Virgin Islands
78	QATAR NATIONAL	Qatar
79	QORNOQ	South Greenland
80	REUNION	Mascarene Island
81	ROME 1940	Sardinia Island
82	RT 90	Sweden
83	PROVISIONAL SOUTH AMERICAN 1956	Bolivia, Chile, Colombia, Ecuador, Guyana, Peru, Venezuela
84	SOUTH AMERICAN 1969	Argentina, Bolivia, Brazil, Chile, Colombia, Ecuador, Guyana, Paraguay, Peru, Venezuela, Trinidad, Tobago
85	SOUTH ASIA	Singapore
86	PROVISIONAL SOUTH CHILEAN 1963	South Chile
87	SANTO (DOS)	Espirito Santo Island
88	SAO BRAZ	Sao Miguel, Santa Maria Islands (Azores)
89	SAPPER HILL 1943	East Falkland Island
90	SCHWARZECK	Namibia
91	SOUTHEAST BASE	Porto Santo and Madeira Islands
92	SOUTHWEST BASE	Faial, Graciosa, Pico, Sao Jorge, and Terceira Islands (Azores)
93	TIMBALAI 1948	Brunei and East Malaysia (Sarawak and Sabah)
94	TOKYO	Japan, Korea, Okinawa
95	TRISTAN ASTRO 1968	Tristan da Cunha
96	NOT USED	
97	VITI LEVU 1916	Viti Levu Island (Fiji Islands)
98	WAKE-ENIWETOK 1960	Marshall Islands
99	WORLD GEODETIC SYSTEM 1972	
100	WORLD GEODETIC SYSTEM 1984	System default
101	ZANDERIJ	Surinam
102	CH-1903	Switzerland
103	HU-TZU-SHAN	
104	INDONESIA 1974	Indonesia
105	AUSTRIA	Austria
106	POTSDAM	Germany
107	TAIWAN (MODIFIED HU-TZU-SHAN)	Taiwan

14. Interfacing details

Interfacing uses standard NMEA 0183 sentences. Some manufacturers have introduced variants which require a setting as in Section 11.1.5.

Details of connections to sample GPS units are at the end of this Handbook. Datasheets on most GPS and other units are held by YEOMAN and available from them, a dealer or the YEOMAN website.

An optional Power input cable and connector (2-pin) may be used. This is connected internally in parallel to the power elements (red and thin black) of the Power/Data cable.

When power is supplied, say from a cigarette lighter socket, on the Power input connector then power may be taken off the (red and thin black) elements of the Power/Data cable, for instance to provide power to a hand-held GPS.

In the following diagrams, power input is shown on the Power/Data cable unless otherwise stated.

14.1 YEOMAN Sport

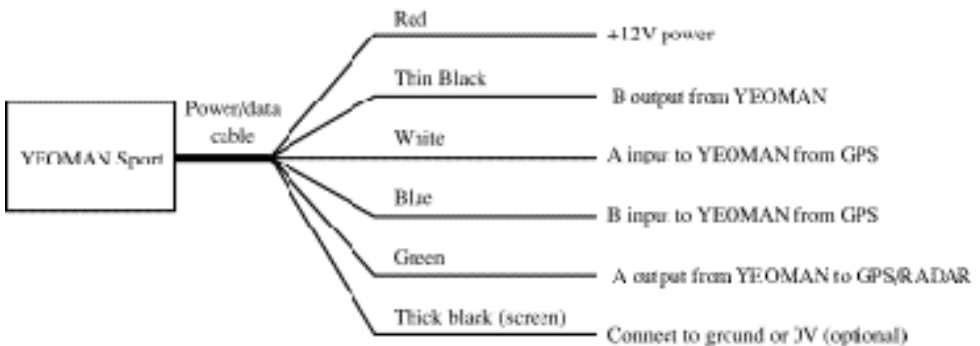

If the GPS has a two wire output, i.e. Data out A (or +) and Data out B (or -) then connect Data out A to the YEOMAN White and Data out B to the YEOMAN blue.

If the GPS has a single wire output (Data out) then connect this to the YEOMAN white. The YEOMAN blue is in these cases connected to 0 volts i.e., the same point as the YEOMAN thin black.

If the GPS has a two wire input, i.e. Data In A (or +) and Data In B (or -), then connect Data In A to the YEOMAN green. Data In B will need to be connected with a link wire to 0 volts i.e., the same point as the YEOMAN thin black.

If the GPS has a single wire input, (Data In) then connect this to the YEOMAN green.

14.1.1 YEOMAN Sport XL RADAR connections

The NMEA 0183 data out can be connected to a RADAR.

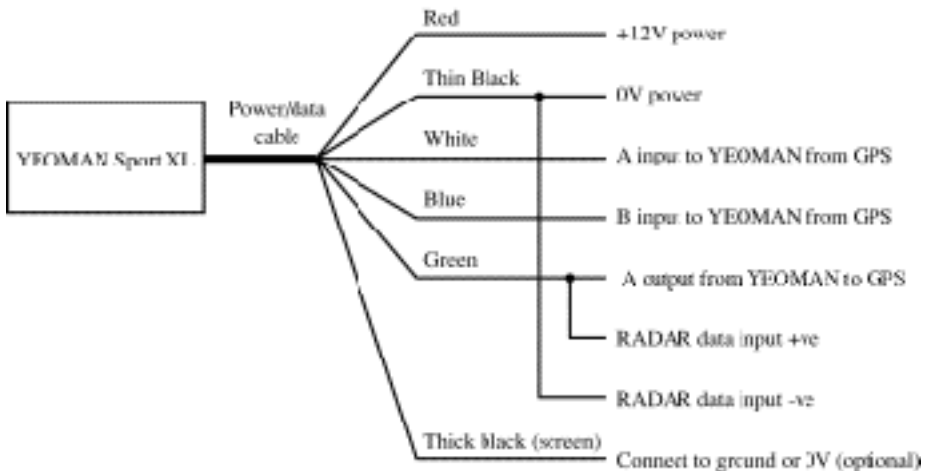

14.2 YEOMAN GPS Sport XL

Standard connections are shown in Section 2.2.2. In order to connect a RADAR or autopilot it is necessary to break into the interconnect cable, which may be extended as necessary. The following diagram gives guidance on the connections; power input via the Power cable is not shown.

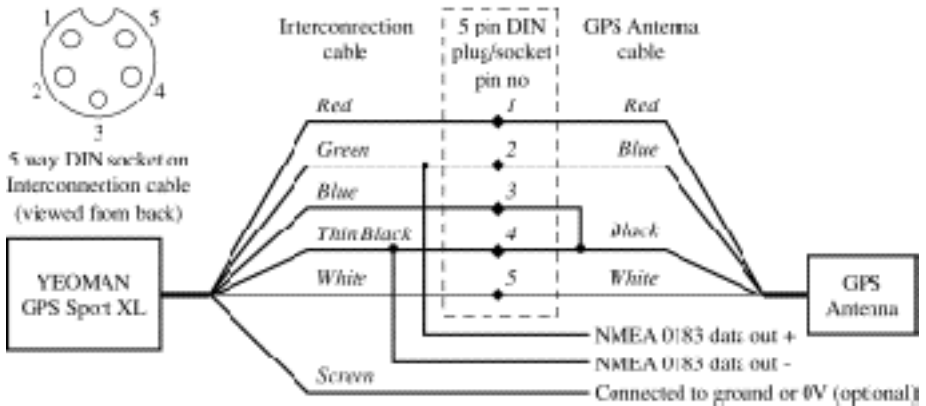

The NMEA 0183 data out can be connected either to an autopilot or to a RADAR.

14.3 RADAR data change-over switch (GPS XL and XL)

To allow normal Waypoint plotting and YEOMAN Waypoint plotting a change-over switch on the input to the RADAR should be fitted as follows:



15. Specifications

15.1 YEOMAN Sport and YEOMAN Sport XL

Power supply	10-15 volts DC, 250mA
Operating temperature	0-45 °C
Display (on Mouse)	LCD, 90° viewing angle
Function controls	7 tactile keys
Illumination	LCD backlighting and chart light
Overall dimensions	675 x 495 x 50 mm
Active area	515 x 380 mm
Weight	2.4 kg
Plotter resolution	Better than 2mm
Chart projections	Mercator and port plans
Chart library	100 User charts, 100 Waypoints
Waypoint library	100 Waypoints
Memory retention	Minimum 36 months
External NMEA 0183 interface	4800 Baud, 8 data bits, 1 stop bit, no parity Output: TTL levels (0V and 5V) Input: opto-isolated, 0V and 2V(min) to 20V (max) Maximum reverse voltage 20V Maximum current requirement: 50mA (at +20V)
Input (NMEA 0183)	Sentences: GGA, RMC, GLL, VTG, VHW Prioritised in order shown
Output (NMEA 0183)	Sentences: WPL GLL on * key in YEOMAN mode VTG, BWC - Sport XL only, RADAR plotting

15.2 YEOMAN GPS Sport XL

The specifications for the YEOMAN GPS Sport XL are the same as for the YEOMAN Sport XL except for the following:

Power consumption	300 mA, normal operating mode
GPS antenna dimensions	57 x 97 x 37mm
GPS antenna weight	0.125 kg
Chart datums	101
GPS Receiver	Tracks and uses up to 12 satellites
Output (NMEA 0183)	Sentences: As YEOMAN Sport XL, plus GGA, RMC, XTE
Time to fix:	
Reacquisition	Less than 2 seconds
Warm	15 seconds, all data known
Cold	45 seconds, position, time and almanac known
Sky search	5 minutes, no data known
Update rate	1 second
Accuracy	15 metres RMS, reduced to 100 metres 2 DRMS with Selective Availability (SA)

Appendix A: YEOMAN to Garmin GPS 12XL,11, 111,45

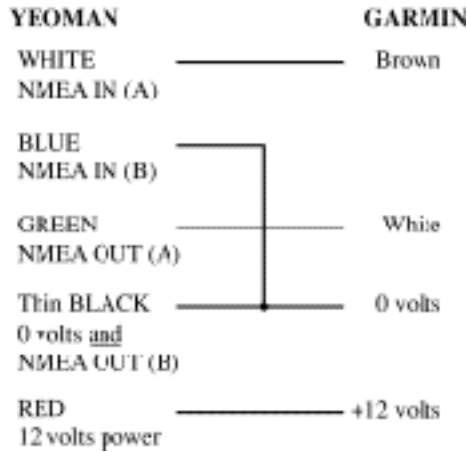

YEOMAN screen (braiding or thick black wire) is optional.
Connect to ship's ground or 0 volts.

YEOMAN Sport setup

NMEA-0183 (factory default)

Garmin setup

Use I/O set up.

Select: NMEA/NMEA.
NMEA 0183 1.5
4800 baud

Appendix B: YEOMAN to GARMIN 120, 120XL, 125, 126, 128, 130, 135, 210, 215, 220, 225, 230, & 235

CONNECTION DETAILS WITH YEOMAN PLOTTER

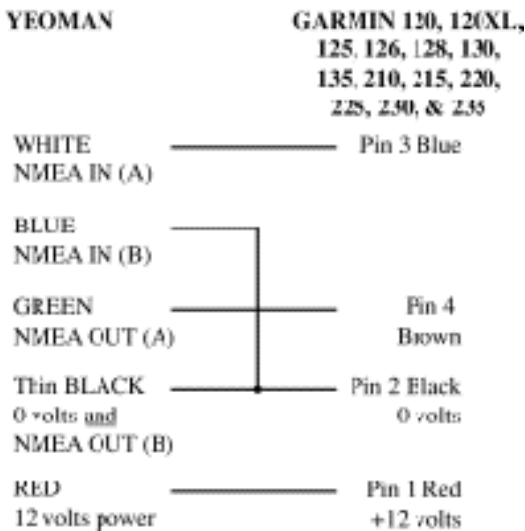

YEOMAN Thick BLACK (screen) is optional. Connect to ship's ground or 0 volts

YEOMAN SETUP:

NMEA-0183 (factory default)

GARMIN SETUP See page 45-46 in GPS 120 manual; page 54 in 120xl manual. Always make sure that you use I/O setup.

Select NMEA/NMEA
 NMEA 0183 1.5
 4800 baud

Note that Garmin software version 2-00 or later will accept waypoints from the YEOMAN. Note also that some early GPS units were shipped with interface cables with different coloured wires from the above, if so contact for an updated interface cable.

Appendix C YEOMAN to Philips AP8 & AP9 GPS

YEOMAN		AP8 & AP9
WHITE NMEA IN (A)	—————	3 RED in cable marked 'NMEA Out'
BLUE NMEA IN (B)	—————	1 Smooth wire in 'MOB' cable
GREEN NMEA OUT (A)	—————	2 RED in cable marked 'NMEA In'
	—————	7 BLUE in cable marked 'NMEA In'
Thin BLACK 0 volts and NMEA OUT (B)	—————	5 BLACK in power cable
RED 12 volts power	—————	9 RED in power cable

YEOMAN screen (braiding or thick black wire) is optional.
Connect to ship's ground or 0 volts.

YEOMAN Sport setup

NMEA-0183 (factory default)

AP8 & AP9 setup

None required

The display of a Waypoint will not update after a Waypoint has been sent until you scroll away from it and back.

Appendix D: YEOMAN to PC

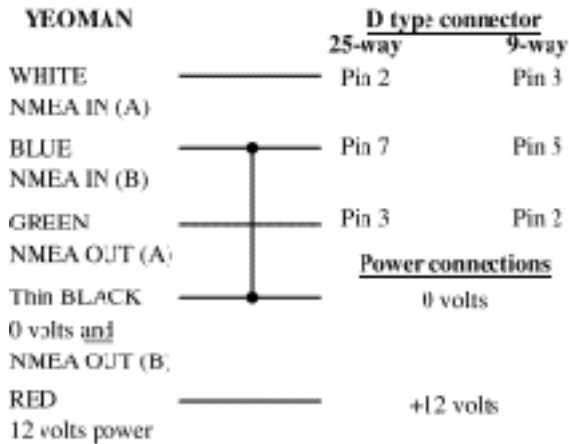

YEOMAN screen (braiding or thick black wire) is optional. Connect to ship's ground or 0 volts.

Caution

Applicable when PC is powered from DC source only. This wiring connects the logic ground of the PC to ship's 0 volts. On some PC's this may cause damage to the PC. Seek advice from PC manufacturer or arrange to power PC from supply isolated from ship's 0 volts.